

4

3

2

1

REVISION HISTORY				
ZONE	REV	DESCRIPTION	DATE	APPROVED

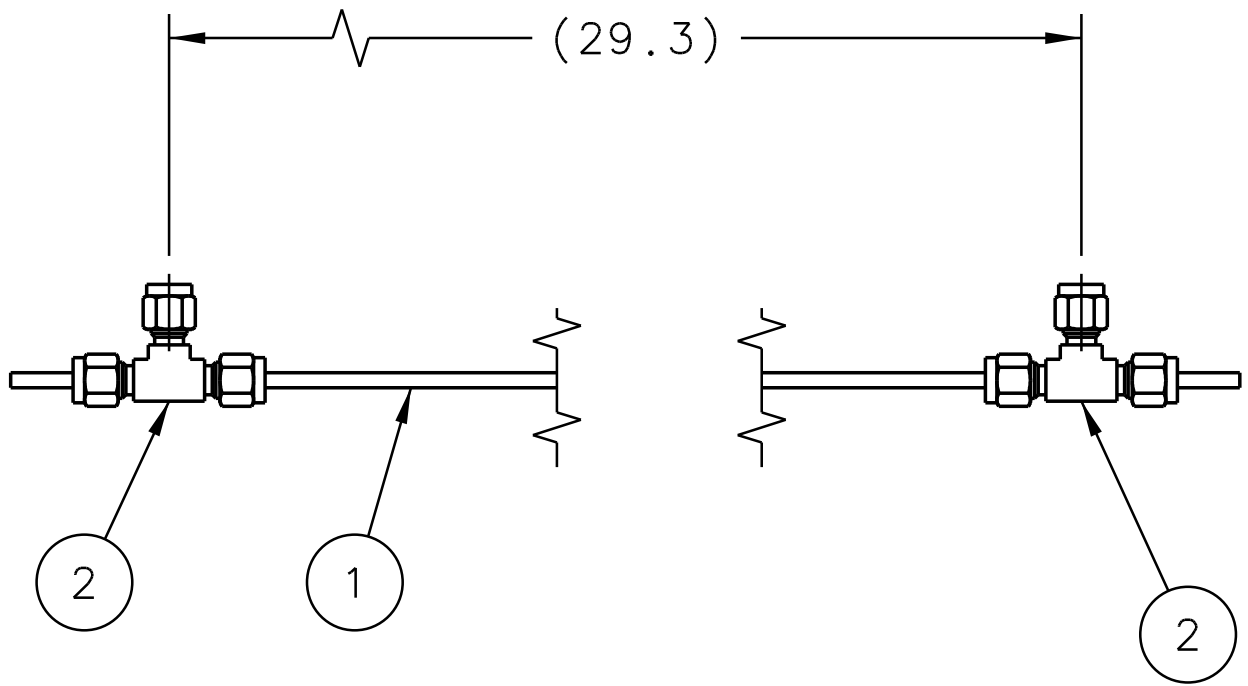
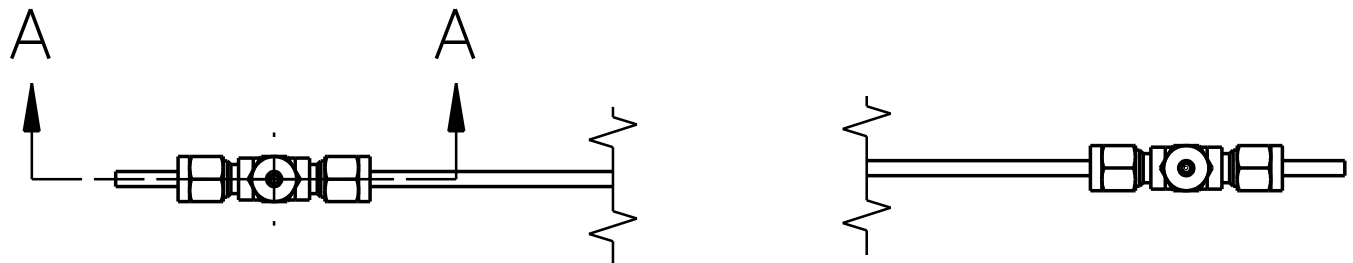
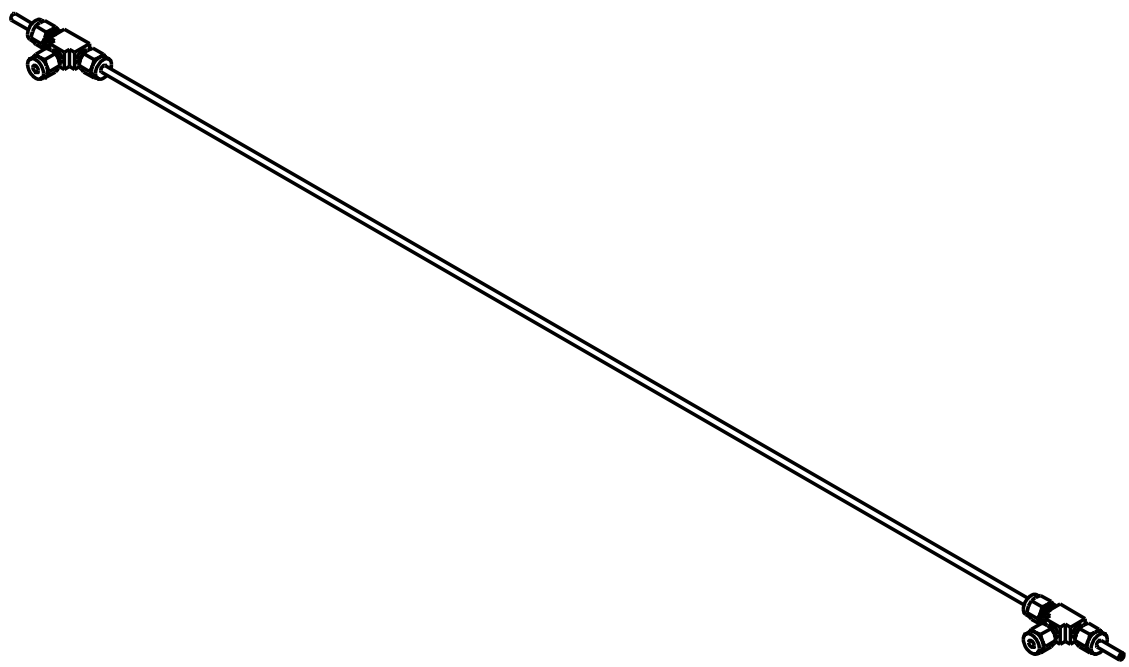

NOTES:

- 1. SUGGESTED SOURCE OR JLAB APPROVED ALTERNATE:  
DIBERT WWW.SWAGELOK.COM (804) 275-7871

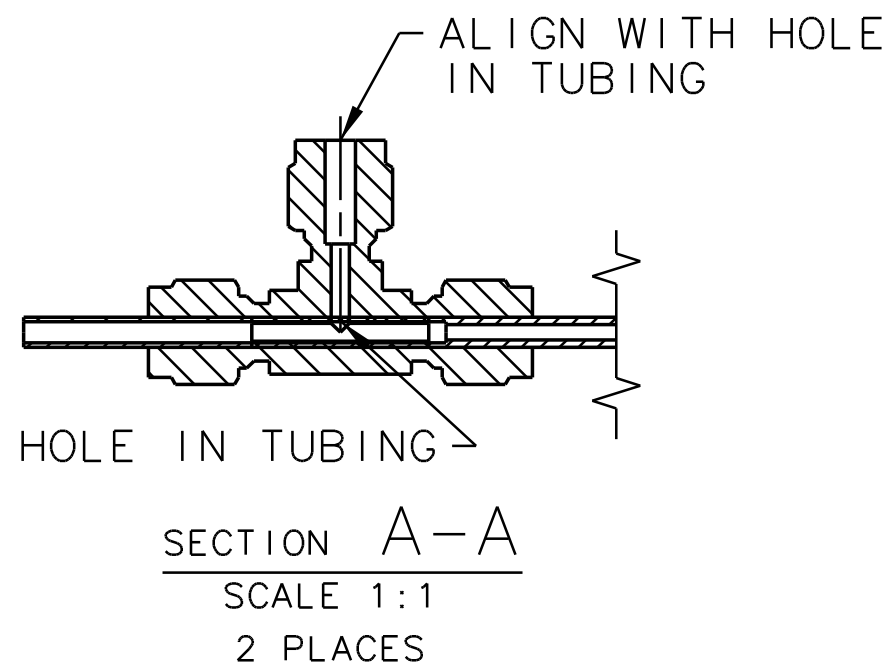

QTY RECD	ITEM NO.	PART OR IDENTIFYING NO.	NOMENCLATURE OR DESCRIPTION	MATERIAL SPECIFICATION	NOTES
2	2	SWAGELOK B-4M0-3	UNION TEE -4MM	BRASS	1
1	1	D00000-13-03-2020	TUBE-4 MM OD TAPPED		

PARTS LIST

DOCUMENT CONTROL STAMP	DTM & TOL PER ASME Y14.5 - UNLESS OTHERWISE SPECIFIED DIMENSIONS ARE IN INCHES TOLERANCES ARE:	TRACKING NO. N/A		United States Department of Energy <b>Jefferson Lab</b> <small>Thomas Jefferson National Accelerator Facility</small> Newport News Virginia
	MATERIAL SEE PARTS LIST	FRACTIONS DECIMAL ANGLES ± N/A .X ± .1 ± .50° .XX ± .01 .XXX ± .005	APPROVALS DATE	
FINISH MACHINED SURFACES N/A UNLESS OTHERWISE NOTED DEBURR & BREAK ALL SHARP EDGES	THIRD ANGLE PROJECTION	DRAWN R. GETZ CHECKED C. HUTTON APPROVED W. CRAHEN APPROVED T. WHITLATCH	DATE 30JAN13	SIZE DWG. NO. C D00000-13-03-1010 REV. -
DO NOT SCALE DRAWING			SCALE 1:2	USED ON ASSY NO D00000-13-03-1007 SHEET 1 OF 1