

FREQUENCY TUNING OF THE CEBAF UPGRADE CAVITIES*

J.R. Delayen, L. Doolittle, E. Feldl, V. Nguyen[#], and W. Sachleben,
 Thomas Jefferson National Accelerator Facility, Newport News, VA

Abstract

Long-term plans for CEBAF at Jefferson Lab call for achieving 12 GeV in the middle of the next decade and 24 GeV after 2010. In support of these plans, an Upgrade Cryomodule capable of providing more than twice the voltage of the existing ones is under development. One requirement is to operate the superconducting cavities, which are 40% longer than existing ones, at 2.5 times the original design gradient with the same amount of rf power. This puts stringent requirements on the accuracy of the frequency tuner: range of 400 kHz and resolution of 1 Hz. A new tuner design to meet these requirements is under development. This system avoids problem areas of previous designs by holding to the principles of not placing moving parts in the vacuum and / or low temperature space, and of having all drive components readily accessible for maintenance and replacement without cryomodule warm up.

1 INTRODUCTION

In a superconducting accelerator, the frequency tuners perform several functions: bring the cavities on resonance after installation and cooldown, detune the cavities that are not operating, and track the changes in frequency due to Lorentz detuning, pressure, and temperature fluctuations. For the CEBAF Upgrade Cryomodule [1], the band width will be small (~ 75 Hz), the Lorentz detuning large (~ 500 Hz), and we want to track the frequency accurately (~ 2 Hz) in order to minimize the rf power requirements.

The cost of removing a cryomodule from the accelerator tunnel for disassembly and repair is considerable. Add the beam time lost and the interruption of experiments and it is then quite obvious that the operating reliability of the tuner is of great importance. The cavity tuner is a mechanism with obvious potential for failure, since it continuously adjusts the length of the cavity to keep it in tune to the operating frequency of the accelerator

2 TUNER REQUIREMENTS

The cavities in the CEBAF Upgrade Cryomodule will differ from the existing ones in several respects: they will be 40% larger (7-cell instead of 5-cell) and have a design gradient of 12.1 MV/m instead of 5 MV/m.

In spite of having an energy content 7 times larger at design field, we have adopted as a goal only a modest increase of the rf power per cavity from 5.5 to 6 kW.

As shown in Figure 1, in order to operate at 12.5 MV/m with a circulating current of 400 μ A, the total amount of detuning, both static (average frequency offset) and dynamic (microphonics) must not exceed 25 Hz. This would give sufficient margin for rf control and allow for errors in the external coupling. For this reason, the frequency tuner will be required to achieve a frequency resolution of 1 Hz. Because the needed resolution is much less than the Lorentz detuning (~ 500 Hz) and the sensitivity to pressure fluctuations (~ 100 Hz/torr), the cavity frequency may need to be adjusted frequently without impact on operation. It is unlikely that a pure mechanical tuner, similar to the one in use at CEBAF, would fulfill the requirements because of the associated vibration, deadband, backlash, and non-monotonicity.

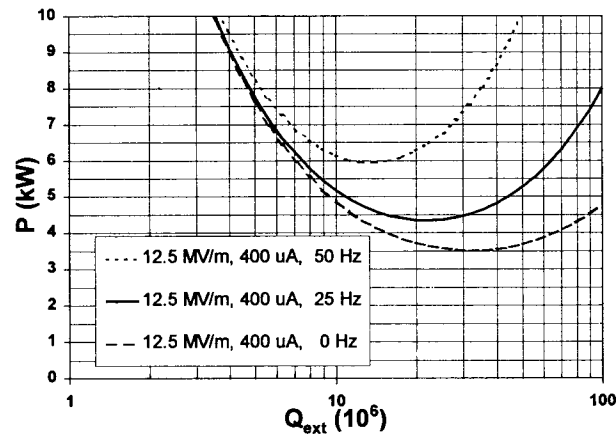

Fig.1: Required rf power vs external Q at the design gradient of 12.5 MV/m, design current of 400 μ A and maximum detuning of 0, 25 and 50Hz.

On the other hand, the tuning range must be adequate (± 200 kHz) to compensate for variability in manufacturing, chemical processing, and cooldown; and to allow for substantial detuning of cavities that are not operating.

In order to satisfy these requirements, the tuning system has been divided into two parts: a coarse tuner with a range of ± 200 kHz and resolution of 100 Hz, that is expected to be used infrequently, and a fine tuner with a range of ± 1 kHz and resolution of 1 Hz that will be used during normal operation.

* Work supported by the U.S. Department of Energy under contract DE-AC05-84-ER40150.
[#] Email: nguyen@jlab.org

3 TUNER DESCRIPTION

The fine tuner makes use of piezoelectric actuators to avoid the friction on mechanical components that would otherwise adversely affect the resolution and the life expectancy of the mechanism. The fine tuner can therefore be used for continuous small corrections to the cavity frequency, over its range of ± 1 kHz. The coarse tune adjustment of ± 200 kHz is actuated by a stepping motor through a harmonic drive reducer and a ball screw. Both systems are external to the vacuum enclosure, and are at ambient temperature and therefore accessible for maintenance and repair. The tuning motion of either drive system is brought into the cryostat through two thin-wall concentric tubes (Items 1 & 2, Fig. 2), both moving axially and relative to one another. From that linear motion feedthrough, all other tuning motion is generated using metal flex joints only. The tubes are connected respectively to the upper and lower arms (Item 3 & 4, Fig. 2) of a scissors type jack and in this way the motion of the tubes translates into a linear stroke parallel to the cavity center line.

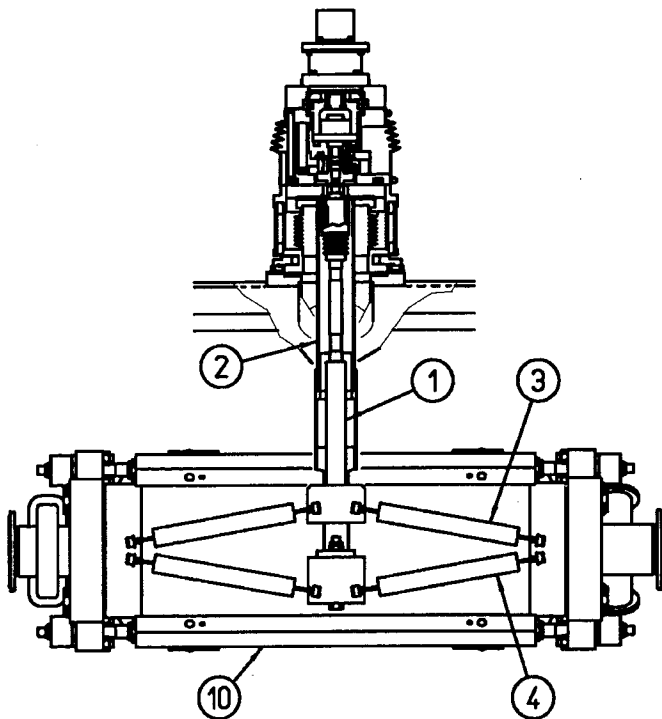

Fig. 2: Scissors Type Jack

The niobium cavity (Item 5, Fig. 3) has two reinforcing and attachment rings (Item 6, Fig. 3), one on each end of the seven-cell array, with each having a wedge-shaped groove machined into its outside surface for positive

attachment points. There is a split-ring clamp (Item 7, Fig. 3) engaging each of these that is used to mount the tuner. Titanium flex inserts (Item 8, Fig. 3) connect the split rings to two pivot plates (Item 9, Fig. 3), one on each end of the cavity. At the midpoint of these plates, two compression bars (Item 10, Fig. 1), extend from one plate parallel to the cavity center line to the other plate, providing fulcrum points for both pivot plates. Titanium flex inserts again are used at the connecting points of this arrangement. The other end of these pivot plates are fastened to the above described scissors type jacks, again using flex inserts, to complete the power train of the system.

The cavities are manufactured 1.5 mm shorter than their in-tune length, so that the tuner components are in tension at all times, to provide a backlash free tuning range. The fine tuning actuators are three piezoelectric post type units (Item 11, Fig. 4), located between the upper and lower mounting plates (Item 12 & 13, Fig. 4). They are spaced uniformly around the ball screw nut (Item 14, Fig. 4) and work in compression only. They are low voltage units (150 VDC) with a stroke of 50 μ m.

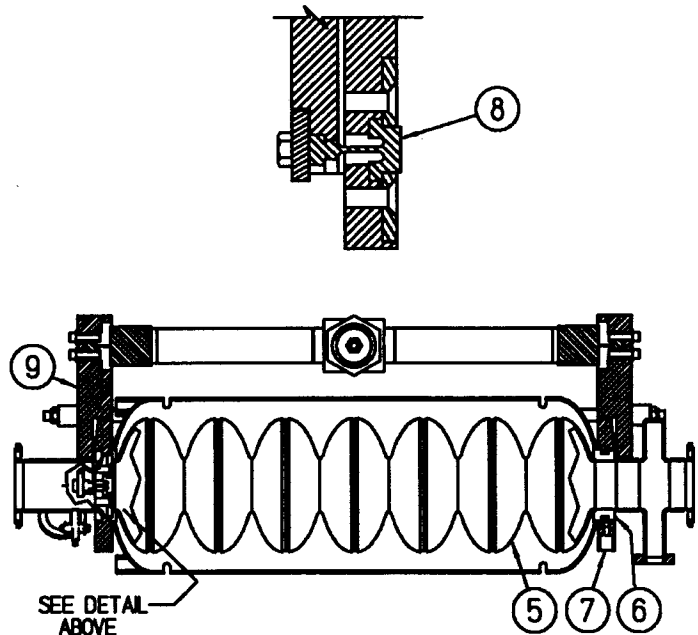

Fig. 3: Pivot Plate Arrangement

The scissors jack, pivot plates and split rings are machined from 6AL/4V titanium, which has similar coefficient of thermal expansion to niobium. The thrust tubes are made of type 304 stainless steel, and have thin wall areas to minimize thermal conduction to the cavities.

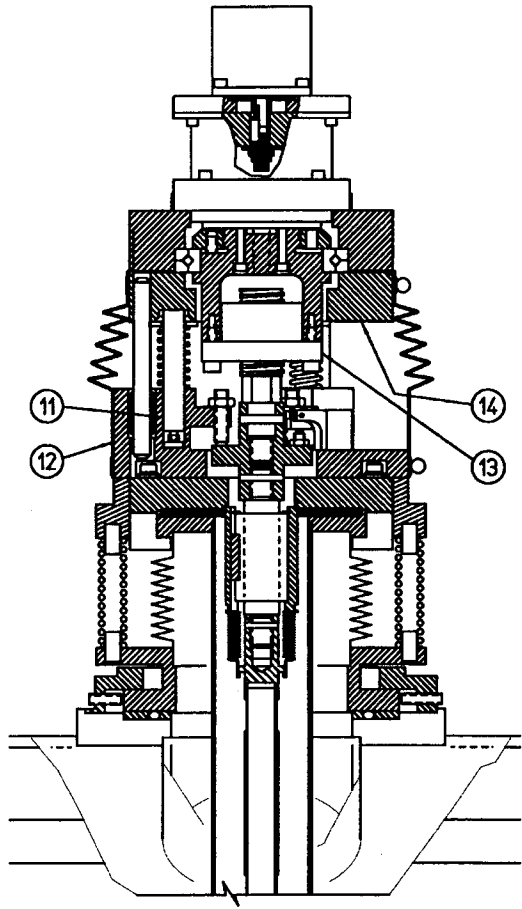

Fig. 4: Drive Assembly

4 CONCLUSIONS

A Horizontal Test Bed is being constructed to perform demonstration tests on different key components for the Energy Upgrade Cryomodule (tuner, coupler, and cavity). A prototype of the tuner is under construction and testing in this Horizontal Test Bed is scheduled to begin in July of this year.

5 ACKNOWLEDGEMENTS

We would like to thank the members of the Upgrade Cryomodule Development team for their helpful discussions.

6 REFERENCES

[1] J.R. Delayen "Upgrade of the CEBAF Acceleration System" these proceedings