

REVISIONS				
ZONE	REV.	DESCRIPTION	DATE	APPROVED
A		DIM. .760/.755 WAS .655/.665, EXTENDED DIA DIM. LINES	01/23/97	LDT
B		ADD L TO BOTH PORTS. DIM Ø1.075 WAS Ø1.175	05/10/97	LDT
C		CHG NOTE 2. REF. ACHIEVING FINISHES & ADD NOTE 5 - ROUGH CUT CAVITY DIM.	5-22-97	<i>[Signature]</i>

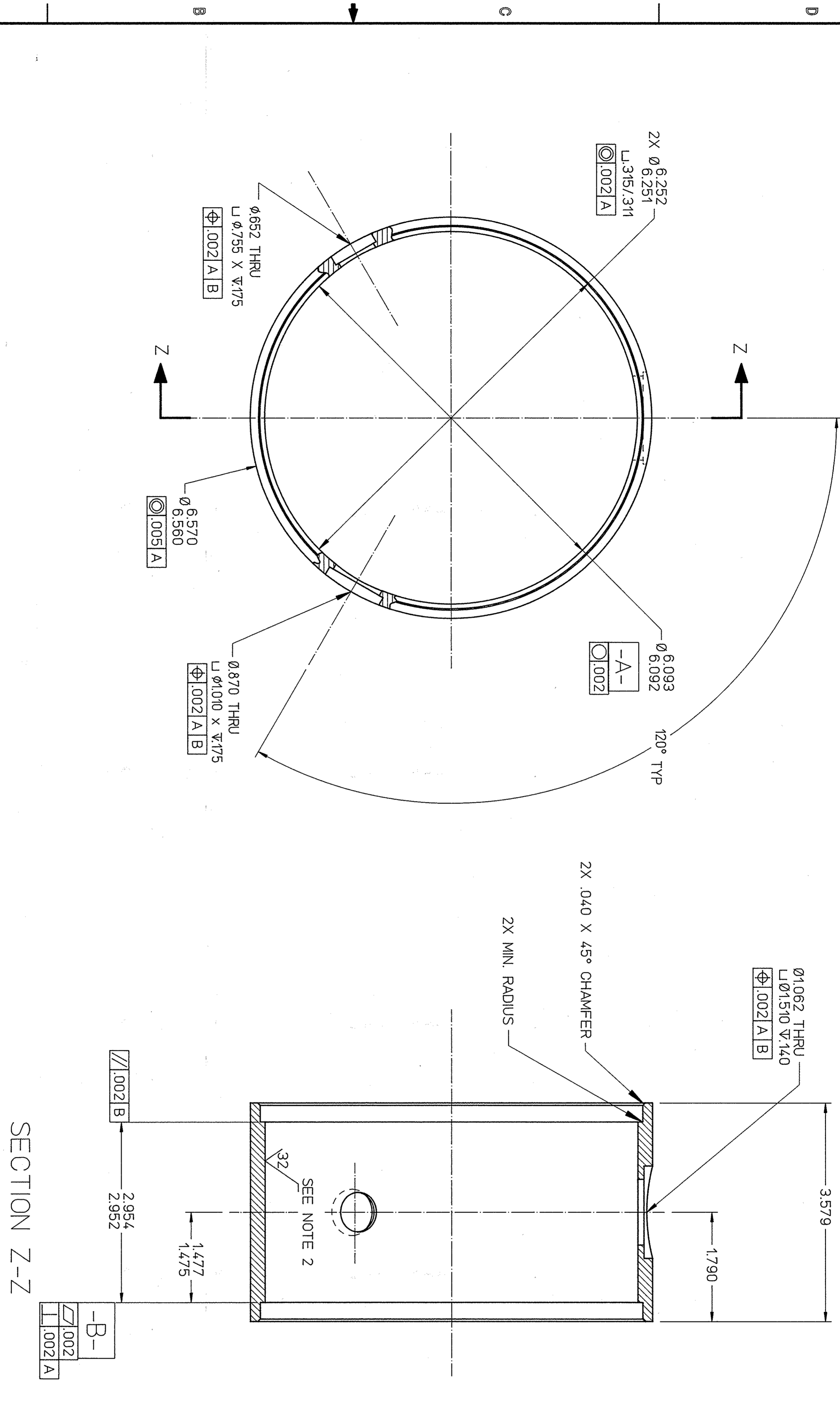

SECTION Z-Z

- NOTES:
1. ALL MACHINING, HANDLING AND CLEANING TO MEET CERAF SPEC Z2631-S-001 & Z2632-S-001.
 2. NO SANDING, POLISHING OR THE USE OF ANY ABRASIVE ALLOWED TO ACHIEVE SPECIFIED FINISHES. REQUIRED FINISH TO BE ACHIEVED BY MACHINING ONLY.
 3. A MATERIAL CERTIFICATE REQUIRED.
 4. MANUFACTURING CERTIFICATE REQUIRED FROM FABRICATOR.
 5. ROUGH CUT BORE TO 6.4 O.D. & 6.0 I.D. X 4.0 LONG. STRESS RELIEVE AT 600°F TO 750°F, AIR COOL.

REV.	DATE	DESCRIPTION	BY	CHKD.
1	01/23/97	ISSUED FOR FABRICATION	LDT	LDT
2	05/10/97	ADD L TO BOTH PORTS. DIM Ø1.075 WAS Ø1.175	LDT	LDT
3	5-22-97	CHG NOTE 2. REF. ACHIEVING FINISHES & ADD NOTE 5 - ROUGH CUT CAVITY DIM.	<i>[Signature]</i>	LDT

DESIGNED BY	DATE	APPROVED
JACKI R. SMITH	12/7/96	<i>[Signature]</i>
CHECKED BY	DATE	APPROVED
L. TURLINGTON	01/02/97	<i>[Signature]</i>
DRAWN BY	DATE	APPROVED
JACKI R. SMITH	12/7/96	<i>[Signature]</i>
CHECKED BY	DATE	APPROVED
L. TURLINGTON	01/02/97	<i>[Signature]</i>
DRAWN BY	DATE	APPROVED
JACKI R. SMITH	12/7/96	<i>[Signature]</i>

SIZE	DWG. NO.	REV.
D	39200-D-0172	C
SCALE	ISSUED ON ASSY NO.	SHEET
FULL	39200-E-0171	1 OF 1

