

REVISION HISTORY		
ZONE	REV	DESCRIPTION

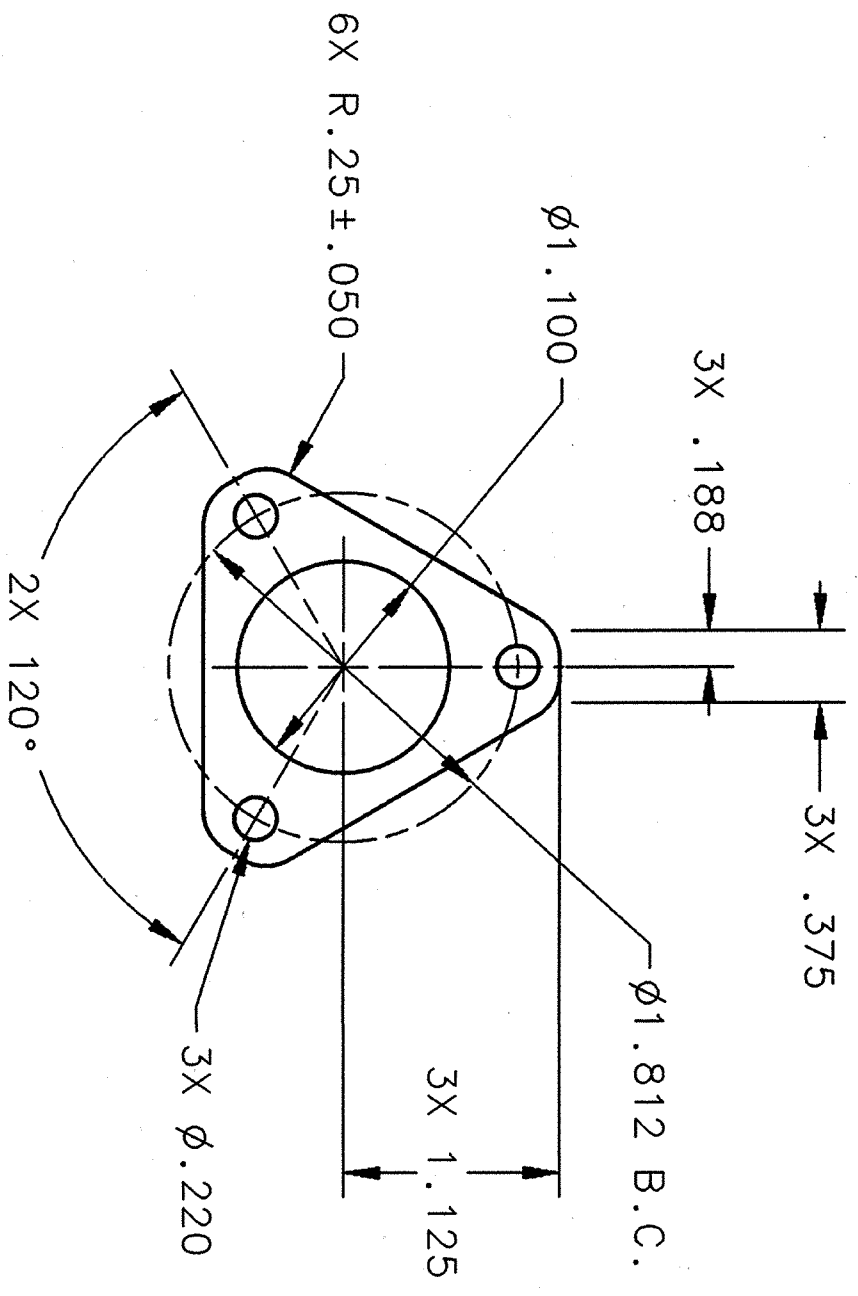

- NOTES:
1. FABRICATE SHIELD PER SOW #CRM900 00 00-1011.
 2. CLEAN AND HANDLE PER TJNAF SPEC: 11141-S-0034.

<p>DIM & TOL PER ANSI Y14.5 UNLESS OTHERWISE SPECIFIED DIMENSIONS ARE IN INCHES TOLERANCES ARE:</p> <p>FRACTIONS DECIMAL ANGLES</p> <p>#N/A .XX ±.02 ±1°</p> <p>.XXX ±.005</p>		<p>CADD I.D. NO.: I-DEAS</p> <p>SNS DRAWING NO. 104100206-M8B-8200-A038-R00</p>		<p>Thomas Jefferson National Accelerator Facility NEWPORT NEWS, VIRGINIA UNITED STATES DEPARTMENT OF ENERGY</p> <p><i>Jefferson Lab</i></p>	
<p>MATERIAL</p> <p>STAINLESS STL TYPE 304</p>		<p>APPROVALS</p> <p>DATE</p>		<p>SPALLATION NEUTRON SOURCE CRYMODULE 50K SHIELD SHIELD BELLOWS PLATE - DETAIL</p>	
<p>FINISH 125 UNLESS OTHERWISE NOTED</p> <p>DEBURR & BREAK ALL SHARP EDGES</p>		<p>DRAWN R. GETZ 05JAN01</p> <p>CHECKED <i>Edward Kelly</i> 11/11/01</p> <p>APPROVED <i>Edward Kelly</i> 11/11/01</p> <p>APPROVED <i>Edward Kelly</i> 11/11/01</p>		<p>SIZE DWG. NO. CRM9005010-1044</p> <p>SCALE 1:1 USED ON ASSY NO. CRM9005010-1042 SHEET 1 OF 1</p>	
<p>DO NOT SCALE DRAWING</p>		<p>DO NOT SCALE DRAWING</p>		<p>REV. -</p>	

