

Design Considerations for Recirculating and Energy Recovering Linacs

David Douglas

Abstract

We discuss performance-related issues in recirculating and energy recovering linacs, give design guidelines for such devices, and present a concept for a two-pass, 10 GeV energy recovering linac that could be used as the basis of a 4th generation synchrotron radiation facility.

Introduction

Success of the energy-recovering SRF driver accelerator for the JLab IR Demo FEL has precipitated interest in the use of such devices in various applications, most particularly nuclear/high energy physics (EIC, eRHIC [1]) and synchrotron sources (ERL [2]). In this note we briefly characterize the nature of these machines, discuss performance limitations experienced with existing machines of this type, and introduce a beam transport design concept that may allow improvements in this area. We close with cursory documentation of a design concept for a multipass, energy-recovered 10 GeV SRF machine that may be an appropriate driver for a 4th generation light source.

Machine Characteristics

The devices under consideration are CW electron linacs based on high-gradient SRF cavities. Present implementations (CEBAF, JLab IR FEL Demo) employ gradient values of order 10 MV/m; proposed machines (ERL) may invoke gradients in excess of 20 MV/m. Machine energies presently range from tens of MeV (IR Demo) to several GeV (CEBAF); proposed machines range in energy from a few hundred MeV (JLab FEL Upgrade) to several GeV (ERL). Beam currents now range from hundreds of μA to tens of mA (IR Demo); extensions to hundreds of mA (ERL) are intended. Resulting beam powers are presently at MW levels, with proposed beam powers of order 1 GW under consideration.

Recirculation and energy recovery are critical to the cost-effective construction and use of such devices. These control startup costs by reducing the number of required (relatively expensive) SRF components and total installed RF power, and limit operational costs by reducing consumed RF power [3]. Practical implementation of these technologies at the enormous beam powers desired of future machines will require appropriate management of the full electron beam phase space throughout the machine. "Lessons learned" in this regard will now be sketched.

Experience At Existing Machines & Potential Performance Limitations

Ancestral implementations of SRF technology (*e.g.*, HEPL) suffered significant performance limitations as a consequence of collective effects such as beam breakup. Experience with these phenomena led to well-defined design principles for both SRF

cavities and accelerator architecture, which, when implemented in later offspring designs (CEBAF and the IR Demo) led to production of far higher currents and beam powers than those available in earlier systems. Examples include fundamental RF power and HOM coupler designs suppressing dangerous modes within cavities, and beam transport lattices providing transverse focusing properties limiting, rather than amplifying, the effect of such modes on the beam. It is now possible – given appropriate evolutionary system design (including, if needed, feedback) – to contemplate the acceleration of very high currents to high energy, thereby generating very high beam powers.

In these circumstances, fundamental beam stability is no longer a performance issue in the machine. Instead, control of beam halo – small regions of phase space outside the beam core – becomes the performance-limiting feature. As an example, the Jefferson Lab IR Demo FEL frequently runs 5 mA beam currents in a system tolerant of $\sim 1 \mu\text{A}$ localized beam loss. “Scraping” at a 2×10^{-4} level thus represents a hard limit (*via* the machine protection system) on beam loss and machine performance; lower beam loss levels are manifested through generation of prompt radiation during beam operations and activation of beamline components.

Halo formation is a complex subject well beyond the scope of this note (and the ability of the author!). However, certain simple observations based on CEBAF and IR Demo operations can give guidance when scaling to systems generating higher beam powers. Regardless of halo formation mechanisms, localized beam loss due to scraping of halo must depend on beam current, beam line component aperture, and the response of the halo to the external focusing applied by the accelerator transport system. Very crudely, the loss should be linear in the current (particularly if the halo is due to single-bunch phenomena and current is doubled by doubling the single-bunch repetition rate without changing the charge/bunch, as in the IR Demo). The loss should also scale inversely with aperture – a smaller hole will generate more loss than a big one. Finally, the halo will tend to be lost where “the beam is big”, or equivalently, where the beam envelope functions (or machine lattice functions) are large. The following expression, in which β is the local beam envelope, a the local beam line aperture, I_{total} the total local current and I_{loss} the beam loss, summarizes these observations.

$$I_{loss} \propto I_{total} \frac{\beta}{a}$$

The proportionality constant can be established using examples from Jefferson Lab operations. The IR Demo runs 5 mA average current and experiences BLM “trips”, indicating $1 \mu\text{A}$ beam loss, at locations with 0.025 m (1”) radial aperture and ~ 5 m beam envelope. This suggests the loss is $\sim 10^{-6}$ times the product of the current and the beam envelope divided by the aperture: $I_{loss} = 10^{-6} \times I_{total} \times (\beta / a)$. An imaginative observer thus might predict, for example, that CEBAF – which runs ~ 0.1 mA in beam transport channels with ~ 0.0125 m radial aperture and peak beam envelopes of order 150 m – should similarly see losses of $\sim 1.2 \mu\text{A}$, a limiting value in fact observed in the machine beam loss accounting system.

Analogous arguments apply to local activation from low levels of scraping; distributed beam loss can also be addressed in this manner, provided average beam envelopes and average apertures are introduced. In all cases, the observation that local (or distributed) loss is correlated with current, beam size, and aperture, suggests that higher power machines must provide some combination of better-limited beam size and greater aperture than available in presently operating systems. Direct application of the above relation would naively suggest that a CEBAF-scale device running 100 mA must provide three orders of magnitude smaller β/a than presently available! This is probably unreasonable; improvements in source technology and beam handling will provide better halo management than that currently available, and localized losses of more than 1 μA are probably tolerable. The message, however, is clear – smaller beam and bigger aperture will be a virtue.

Our attention therefore turns to the issue of beam envelope control. Conceptual studies on CEBAF-type recirculators have suggested that “better” management of beam envelopes could be achieved by limiting the ratio of injected to final energy [4]. Such improvement is, of course, due to reduction of focusing mismatch between the higher energy beams at the reinjection point and the excitation of the magnetic lenses (which are matched to the energy of the injected beam) at that point. For example, CEBAF had a design value of $E_{out}/E_{in} \sim 90:1$, which led to peak beam envelopes of $\sim 200\text{-}300$ m; a later “SUPERCEBAF” design with $E_{out}/E_{in} \sim 10:1$ limited envelopes to peaks of ~ 100 m [5]. Multipass machines are thus performance-limited by the availability of focusing for the higher passes. If the linac lattice is set to focus the first pass beam, once the energy of a higher pass beam exceeds ~ 10 times that of the first pass, the transport appears essentially drift-like. In this case, the “best” peak envelopes available will be the drift (or, as it is here, the linac) length. Generically, machines with low E_{out}/E_{in} and/or short linacs will therefore provide lower peak envelopes and associated better performance (in terms of halo management) than longer, higher relative gain machines.

These conclusions seem to apply reasonably well to CEBAF-scale machines using CEBAF-like SRF parameters. Recent work both at Cornell [6] and Jefferson Lab assuming the availability of very high gradient SRF provides however a more detailed picture and suggests performance improvements can be made that will push beyond the “10:1 energy ratio/peak beta at linac length” barrier. We now relate design features leading to such improvements.

Beam Optical Design Guidelines

Four design concepts particularly applicable to energy recovering linacs have led to beam envelope and beam stability performance quality exceeding that anticipated in the design of ancestral and offspring generations of recirculated SRF machines. A description of each follows.

Graded-Gradient Focusing – Linac designs have historically made use of either constant gradient focusing or constant focal length focusing. The former is most appropriately used in short multipass machines (such as microtrons), the latter has been employed in long single and multipass machines (such as SLAC and CEBAF). Neither technique

provides robust multipass performance in long linacs, particularly if energy recovery is to be used. Use of constant gradient focusing either severely over-focuses the low-energy passes, or provides inadequate focusing of the high-energy passes. Use of constant focal length focusing will (unless a counter-rotating linac topology is used [7]) either under-focus the accelerated beam or over-focus the energy recovered beam.

Graded-gradient focusing addresses this issue by using constant focal length focusing *matched to lowest energy beam present at any given location*. In a single, two-pass (one up, one down) energy recovering linac, this means the quads will increase in field to the midpoint of the linac (being matched to the energy of the accelerating beam) and decrease in field from there to the end of the linac (being matched to the energy of the energy recovered beam). This significantly reduces the linac length over which the beam energy is mismatched to the local focusing; as a result the “beta at linac length” limitation is overcome.

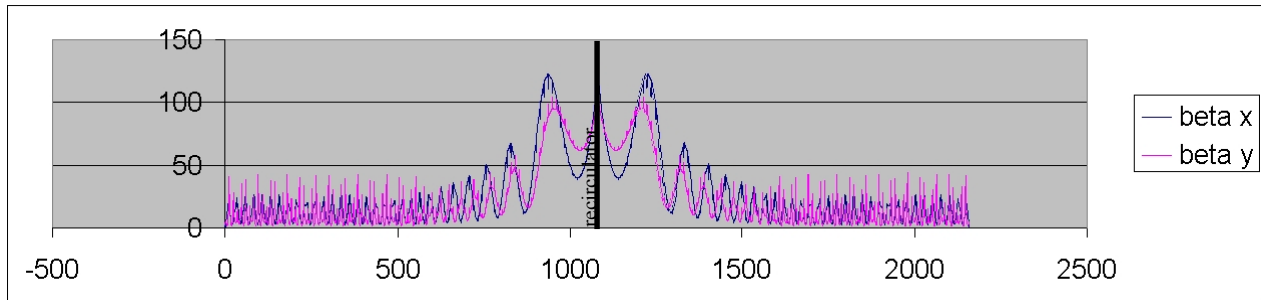

Figure 1: 10 GeV linac optics using graded-gradient focusing.

Figure 1 presents a plot of beam envelopes through an energy-recovering single linac using graded-gradient focusing. Injection energy is 10 MeV, recirculated energy (location of the recirculation arc indicated on the plot) is 10 GeV, dumped energy is 10 MeV. Acceleration is provided using ninety 111 MeV cryomodules (here, based on eleven 1.497 GHz CEBAF 5-cell cavities run at a gradient of ~ 20.2 MV/m). External focusing is provided by quadrupole triplets between the modules; these are adjusted to provide strong focusing of the accelerated (energy recovered) beam on the first (second) pass through the first (second) half of the linac. Injection conditions were adjusted to provide a reasonably period match of the beam to the linac focusing, and the arc transfer matrix was selected to make the beam envelope solution was reflectively symmetric around the high energy point of the machine, thereby ensuring the energy recovered beam would be matched to the linac focusing through the back end of the machine.

Maximum beam envelopes are of order 120 m, despite the E_{out}/E_{in} ratio of 1000:1. This would be unachievable in a linac of ~ 1 km length using conventional focusing methods. Note that in the initial portion of the linac second half, the accelerated beam envelopes actually decline; this is because the focal length is near the stable limit – leading to large “matched” envelopes – in the the first half of the linac. Increasing the energy beyond the minimum local value results in a reduction of focusing, with a resulting reduction in maximum envelopes, until the focusing becomes so weak (in the back end of the linac)

that the accelerated envelopes begin to behave as though being propagated through a drift length. Similar comments apply to the energy recovered envelopes on the second pass.

Use of Very High Gradient SRF – Offspring linac designs such as CEBAF and the IR Demo Driver use gradients of order 10 MV/m to give single cryomodule energy gains of 40 MeV (5-cell) to 60 MeV (projected initial 7-cell). Recent developments in processing of TESLA cavities suggest production gradients of 25 MV/m or higher may be possible. Using high packing fraction cavity geometries (9-cell, etc) cryomodule designs providing 200 MeV energy gain may be possible. This has significant virtue in control of the beam envelopes in a recirculating or energy recovering linac, for two reasons. First, for fixed final energy the linac becomes shorter. The worst case “linac as a long drift beta” value of the linac length is thus reduced. Secondly, consideration of linac focusing geometry reveals it is not the ratio E_{out}/E_{in} that is the figure of merit, rather it is a “focal failure factor” of $f = E_{before\ final\ module}/E_{after\ first\ module}$ that is relevant. This is of course because the initial effective focusing is *after* the first module and *before* the final; focusing before the first module simply changes the injection conditions and after the final simply changes the arc matching/reinjection conditions.

This was not apparent until I. Bazarov [8] considered designs invoking very high gradients, because for “low” gradient systems $f \sim E_{out}/E_{in}$. For example, in CEBAF $E_{out}/E_{in} \sim 90$, while $f = ((4045-20)/(45+20)) \sim 62$. The virtue of both high gradient and graded-gradient focusing is apparent in the Figure 1 system, as average performance exceeds that of CEBAF despite the fact $E_{out}/E_{in} \sim 1000$ and $f = 99$. To illustrate specifically the value of high gradient, we have replicated the 10 GeV linac concept of Figure 1, but using 45 modules at an artificially high gradient of 222 MeV. The beam envelopes for the system are shown in Figure 2; the improvement with a lower focal failure factor ($f \sim 9800/200 = 48$) is evident.

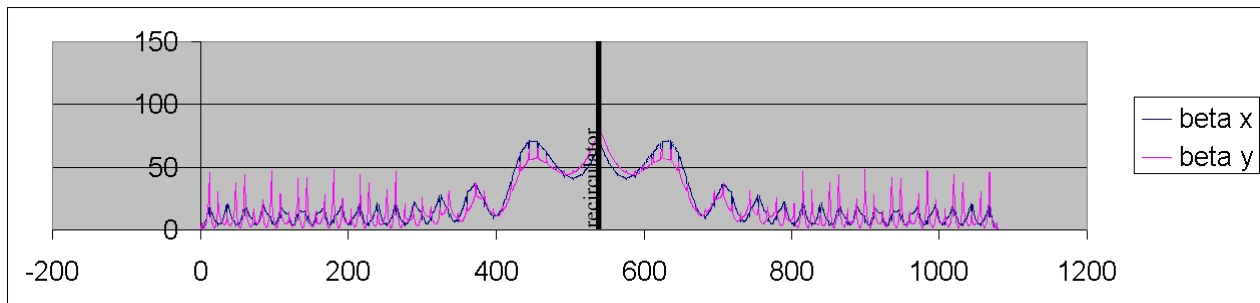

Figure 2: 10 GeV linac with very high (>40 MV/m) gradient acceleration.

“Bisected Linac” Topology – Graded gradient focusing and high gradient acceleration reduce mismatch between local beam energy and local focusing. A simple adjustment in traditional recirculated and energy recovering linac topology can further improve energy/focal strength match. Consider a two pass “traditional” energy recovering split linac. Recirculation and/or energy recovery generally occur with beam transport and acceleration through the first linac, then the second, then back through the first, followed by the second (see Figure 3a). The dynamic range in the first linac is large – with beam at full energy being transported through focusing structure set to manage first pass injected

beam. If however this topology is “bisected”, with full energy beam recirculated to the *second* linac for energy recovery, an improvement of two is achieved in the dynamic range of the first linac, and an even more significant improvement is obtained in the second (see Figure 3b). The order of beam transport is then “first linac, second linac, second linac, first linac”, and the focusing can (particularly with use of graded gradient arrangements) be much more closely matched to the beam energy. This topology can be extended to improve multipass linac performance (see “JERBAL”, below).

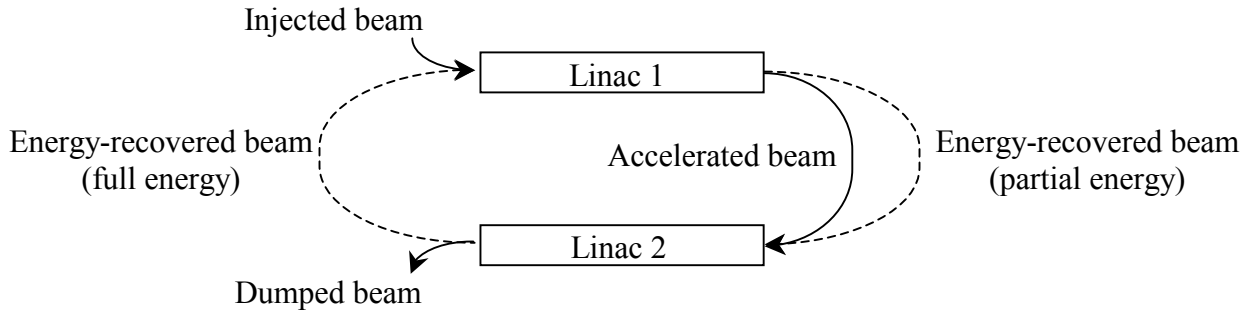

Figure 3a: Traditional linac pair topologies.

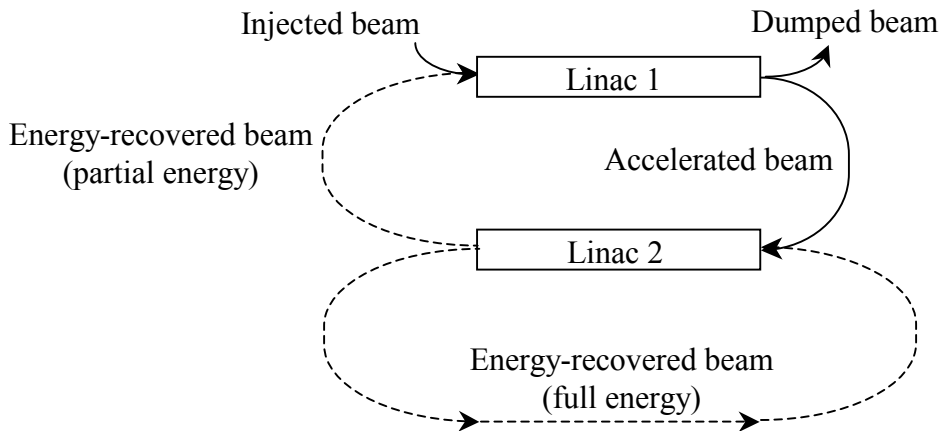

Figure 3b: “Bisected” linac pair topologies.

The full energy recirculation need not be realized in a “figure-8” configuration, but could in practice be in the same tunnel as the first linac. Availability of such extended lengths of beam transport system length at full energy does however provide significant space for interaction regions and/or for placement of insertion devices for the production of synchrotron radiation.

Asymmetrical Gain Linacs – A final technique that can beneficially be used in conjunction with bisecting the linac topology to improve beam envelope performance is the use of asymmetrical gains in the linac pair. As noted above, bisecting the linacs reduces the dynamic range and/or the focal failure factor, with resulting improvement in

peak and average beam envelopes. This advantage can be pressed further by reducing the energy gain of the first linac and increasing the energy gain of the second.

Nominally, the first linac will have low injection and moderate final energy; the second will thus have moderate injection and high final energy. The second linac will therefore, in general, have much better beam envelope control than the first. By reducing the final energy of the first linac, (thereby lowering the injection energy of the second), the dynamic range of the first linac can be improved at the expense of the second, and the system performance thereby optimized. Further, when applied to multipass linac designs, use of asymmetrical gains assists in control of beam envelopes on higher passes through the “lower energy” linac. The first linac beam transport system will provide little focusing on higher passes in multipass machines. Thus, the peak beam envelopes will be, more or less the linac length; limiting the length of this linac by lengthening the other will provide effective management of the peak beam envelopes. As the second linac will have much higher injection energy than the first, it has better dynamic range and will therefore provide better focusing on all passes, with associated greater tolerance of a longer length.

JERBAL - A 10 GeV Linac Driver for a 4th Generation Light Source

In this section we describe a system concept implementing the above design principles. The machine is an energy recovering CW linac intended for use as a 4th generation light source driver; we rather whimsically refer to it as the “Jlab Energy-Recovering Bisected Asymmetric Linacs”, or JERBAL. Machine parameters are given in Table 1. Figure 4 presents the machine topology.

Table 1: JERBAL Machine Parameters	
Machine Topology	4 pass (2 accelerating, 2 energy recovering) bisected asymmetric linac pair
Injection Energy	10 MeV
Final Energy	9.6 GeV
Single pass energy gain	Linac 1: 1.2 GeV Linac 2: 3.6 GeV
Linac accelerating structure	Linac 1: 6 cryomodules Linac 2: 18 cryomodules
Linac focussing structure	triplet, graded-gradient
RF Gradient	25 MV/m
Cryomodule structure	16 5-cell 1.497 GHz CEBAF cavities
Cryomodule energy gain	200 MeV
Current	100 mA
Beam power	Injected 1 MW Full 1 GW Dumped 1 MW

JERBAL comprises a four-pass (two accelerating, two energy-recovering) bisected asymmetrical linac pair, with a 10 MeV injection energy and a nominal final energy of 10 GeV. The first linac consists of 6 200 MeV cryomodules, the second of 18 200 MeV cryomodules; in each the modules are separated by quad triplets excited in a graded-gradient focusing pattern. For the purposes of this study, the modules were modeled as 16 CEBAF 1.497 GHz 5-cell cavities with 25 MV/m energy gain; in practice any cavity configuration providing an active length and gradient appropriate to the desired energy gain can be used.

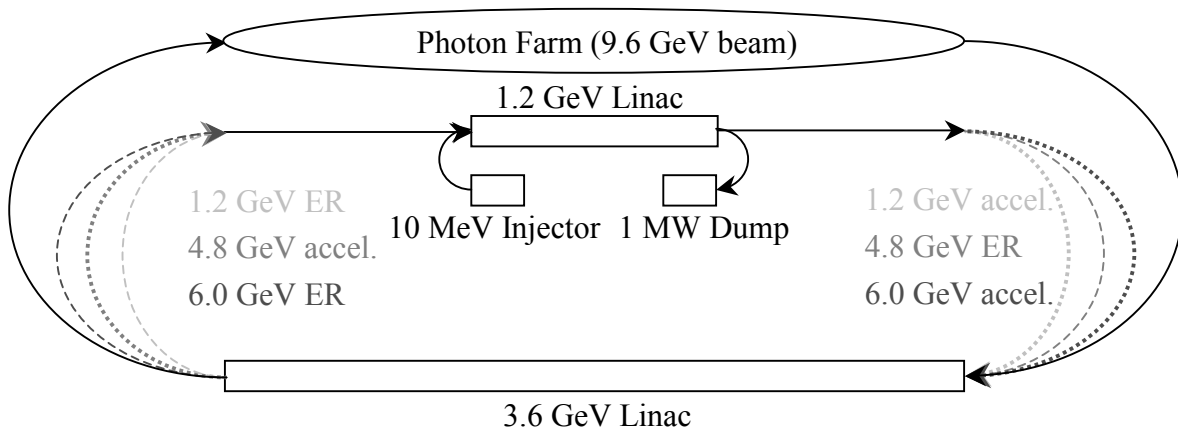

Figure 4: JERBAL Machine Topology

The linacs are joined by a series of recirculation arcs. Accelerated beam at 1.2 and 6.0 GeV and energy-recovered beam at 4.8 GeV are transported at the “right” end of the machine. The pattern is reversed at the left end, with energy recovered beams at 1.2 and 6.0 GeV and accelerated beam at 4.8 GeV being taken from the “long” to the “short” linac. The machine presents a bisected linac geometry, with a full energy transport at 9.6 GeV to a “Photon Farm” positioned in a location topologically equivalent to that of the short linac, with full energy transport back to the long linac for the initiation of energy recovery. As discussed above, this topology provides performance quality exceeding that anticipated by second-generation SRF accelerator designs.

Various arc designs can be accommodated and can be used to simultaneously provide multiple wavelengths of synchrotron light to users while allowing for appropriate electron beam phase space management. It is assumed CSR and other beam quality issues can be adequately addressed. The full energy transport can, as noted above, be housed in the 1.2 GeV linac vault; however, the design concept provides significant flexibility with many possible implementations for (extensible/upgradeable) photon production areas. Figure 5 presents beam envelopes through the system; locations of various recirculation arcs are indicated. As in previous plots of this type, linac focusing was chosen to provide good beam envelope control on the first pass and injection/reinjection conditions selected to manage higher pass envelopes. The driftlike behavior of beam envelopes during higher passes through the low energy linac is apparent.

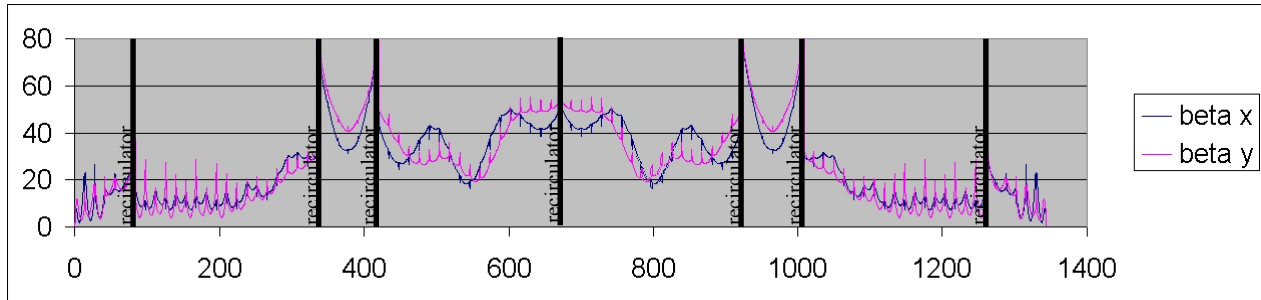

Figure 5: JERBAL beam envelopes.

Acknowledgements

I would like to thank Ivan Bazarov (of Cornell University), Geoff Krafft, Lia Merminga, George Neil, and Mike Tiefenback (all of Jefferson Lab) for useful discussions on these topics.

References

- [1] L. Merminga, private communication; I. Ben-Zvi *et al.*, “Accelerator Physics Issues in eRHIC”, BNL Note C-A/AP/14, 3 April 2000.
- [2] G. Krafft, private communication.
- [3] G. Krafft and L. Merminga, “Efficiency in Energy Recovered Linacs”, draft note (unpublished).
- [4] D. Douglas, “Lattice Design Principles for a Recirculated, High Energy, SRF Electron Accelerator”, Proc. 1993 I.E.E.E. Part. Accel. Conf., Washington, DC.
- [5] *ibid.*
- [6] I. Bazarov, private communication.
- [7] “Counter-rotated” linac layouts allow local matching of focusing to beam energy throughout the acceleration and energy recovery cycle. They are however subject to performance limits from beam-beam interactions; see D. Douglas, “Incoherent Thoughts About Coherent Light Sources”, JLAB-TN-98-040, 13 October 1998. Machines can in principle avoid this issue by separation of counter-propagating beams in the linac structure, but this will require adequate linear aperture in the SRF components to allow beam splitting (as in colliders) and/or adequate longitudinal bunch-to-bunch separation to allow introduction of beam transport components for beam splitting at potential crossing points outside of SRF components. Either requirement reduces the volume of parameter space available to the machine designer.
- [8] I. Bazarov, *op. cit.*