

## CEBAF SUPERCONDUCTING SPECTROMETER DESIGN

Paul Brindza, John Alcorn, Roger Carlini,  
Leigh Harwood, John LeRose, Bernard Mecking,  
Jean Mougey, John O'Meara  
Continuous Electron Beam Accelerator\*  
12000 Jefferson Avenue  
Newport News, VA 23606

Abstract

The CEBAF Experimental Nuclear Physics Program is based upon three independent facilities each with unique capabilities. Hall A consists of a pair of High Resolution Spectrometer (HRS<sup>2</sup>), Hall B features a Large Acceptance Spectrometer (LAS) and Hall C will have a high acceptance, high energy electron spectrometer and matching special purpose hadron spectrometer. We will demonstrate that the performance and operational requirements of these devices can be met effectively through the use of superconducting devices. The Hall A and Hall C spectrometers require high quality, large volume dipole magnets, that although are not beyond the range of conventional magnets, operating considerations favor a superconducting device. The spectrometers require high gradient, large aperture quadrupoles that could not be produced without the use of a superconducting cos 2θ device. The LAS requires a large volume toroidal magnetic field for momentum analysis. The six coils of the Torus must be "thin" to allow the acceptance to reach 80%. This device could be built using a conventional coil but it would not meet the acceptance specification and the operating cost would be prohibitive. The physics requirements and the rational basis for the design selection will be presented. The analysis that supports the cost effectiveness of the selected design will be presented. The cryogenic system will be covered as well as the integration of the Experimental Hall Cryogenic system and main CEBAF Central Helium Refrigerator.

Introduction

CEBAF<sup>1</sup> is a new national research facility for nuclear physics presently under construction in Newport News, Virginia on a site previously occupied by the NASA Space Radiation Effects Laboratory. CEBAF will provide three experimental areas (Hall A, B, and C) to serve the rather wide range of needs of the CEBAF users community. Hall A has been designated the High Resolution Hall and is home to a pair of High Resolution Spectrometers (HRS<sup>2</sup>) whose resolution has been matched to the precision of the electron beam. Hall B is the home of the Large Acceptance Spectrometer (LAS) which is a toroidal-multiparticle spectrometer designed to cover a substantial portion of the entire solid angle. Hall C is the home of general purpose spectrometers with substantial acceptance. The devices are a 6 GeV/c electron spectrometer and a small toroidal spectrometer that will provide for out of plane experiments, kaon physics and the parity violation experiment. Table 1 lists the performance specification of the CEBAF spectrometers. This paper will define how superconductivity has been brought to bear to meet these requirements.

\*Work performed under Department of Energy Contract #DE-AC05-84ER40150.

The three experimental halls are presently in Title I design and are to be under construction within a year. The final design of the spectrometer is underway and a Conceptual Design Report is due by year end. The superconducting magnets<sup>2,3</sup> which represents our major long lead items are having their design completed to allow for procurement from industry beginning in 1989.

CEBAF has engaged in an interactive program with industry in preparation for this procurement for the past two years beginning with the very successful Spectrometer Magnet Workshop<sup>5</sup> held at CEBAF in April 1986. This interaction, which has involved a dozen different manufacturers of superconducting magnets and over 30 individuals, has resulted in a better understanding of the available capability and a clear understanding of CEBAF's requirements and design goals. We at CEBAF are confident that a substantial and capable industrial base exists from which these magnets can be procured at a reasonable cost with a good probability of success.

High Resolution Spectrometer (HRS<sup>2</sup>)

The design of the High Resolution Electron Spectrometer<sup>4</sup> is a natural evolution of a design first proposed by Mougey in 1981<sup>5</sup>. The device shown in Figure 2 is a qQQDQq configuration. The required performance of the spectrometer necessitates the use of superconducting magnets to achieve the required gradient and aperture of the four large quadrupoles. The front quadrupole has extreme space constraints to allow the spectrometer to work at small angle and thus a compact superconducting design was necessary. (See Figure 3.) The dipole's moderate field of 1.7 T and large gap make a superconducting magnet attractive from an electric power consideration but the capital costs in a recent comparison by CEBAF<sup>6</sup> are approximately equivalent. The dipole has evolved

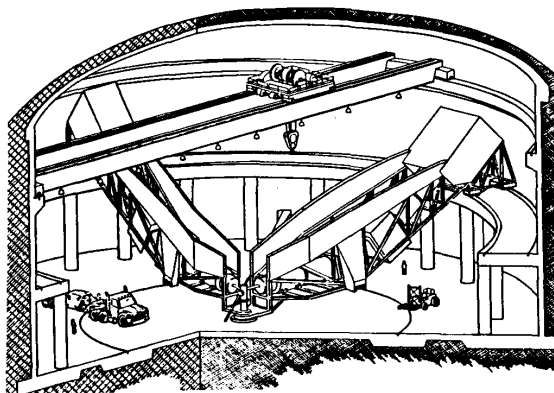

Figure 1: Hall A 185' Diam.

Table II  
Superconducting Magnet Specifications

	Type	Field	Aperture	Length	Quality
<u>HRS<sup>2</sup> Magnets - Hall A</u>					
Q <sub>6</sub>	S.C. Iron	6.2 T/m	16 cm	1.1 m	10 <sup>-8</sup>
Q <sub>1</sub>	Cos 2θ	-3.85 T/m	40 cm	1.8 m	10 <sup>-8</sup>
Q <sub>2</sub>	Cos 2θ	1.91 T/m	40 cm Radius	1.8 m	10 <sup>-8</sup>
Q <sub>3</sub>	Cos 2θ	1.95 T/m	40 cm	1.8 m	10 <sup>-8</sup>
Q <sub>4</sub>	Cos 2θ	-4.49 T/m	40 cm	1.8 m	10 <sup>-8</sup>
D <sub>1</sub>	S.C. H	1.7 T	40 cm x 80 cm	6.3 m	1 gauss/cm

LAS - Hall B

Torus 6-coil iron free	2 T	2m Radius	4 m	10 <sup>-8</sup>
Tagger C-type Dipole	1.5 T	6 cm x 25 cm	2 m	10 <sup>-8</sup>

GPS Spectrometers - Hall C

Electron Spectrometer

QC <sub>1</sub>	S.C. Iron	7.35 T/m	19 cm	1.7 m	10 <sup>-8</sup>
QC <sub>2</sub>	S.C. Iron	5.10 T/m	23 cm	1.7 m	10 <sup>-8</sup>
QC <sub>3</sub>	S.C. Iron	2.25 T/m	23 cm	1.7 m	10 <sup>-8</sup>
DC <sub>1</sub>	S.C. H-dipole	1.7 T	40 cm x 95 cm	3.1 m	1 gauss/cm

Iron Torus

8 coils	S.C.	1.7 T	25 cm x 104 cm	3 m	10 <sup>-8</sup>
---------	------	-------	----------------	-----	------------------

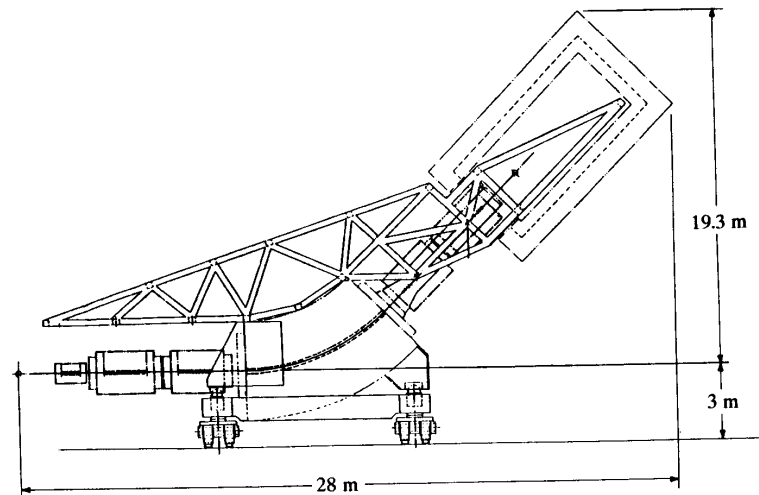

Figure 2: HRS<sup>2</sup>

Table I

## CEBAF Spectrometer Specifications

	$\delta P/P$	$\Delta\Omega$	$\Delta P/P$	$\delta\theta$
<b>Hall A (HRS<sup>2</sup>)</b>				
qQQDQQ (electron)	$1 \times 10^{-4}$	8 MSR	10%	0.1 mR
qQQD (hadron)	$<1 \times 10^{-4}$	7 MSR	10%	0.6 mR
<b>Hall B (LAS)</b>				
Torus (Small Angles)	$5 \times 10^{-3}$	50%	~100%	1 mRad
Large Angles)	$1 \times 10^{-2}$	80%		5 mRad
<b>Hall C (GPS)</b>				
qqqD (electron)	$5 \times 10^{-4}$	5 MSR	20%	0.2 mR
Torus (hadrons)	$<1 \times 10^{-3}$	75 MSR	20%	N.A.

toward a larger (40 cm) gap from the previous design<sup>2</sup> to better match the capabilities of a superconducting coil and to meet a wider range of experimental requirements. Table II lists the magnet requirements for the HRS<sup>2</sup>.

Large Acceptance Spectrometer (LAS)

The Large torus selected to meet the requirements of the LAS was chosen based upon an optimization of the performance.<sup>7</sup> Figure 4 shows the LAS in Hall B. The possible choices for such a device are the torus, the solenoid or a large (1m) gap dipole. The torus provides adequate integral field to give good momentum resolution over 80% of the solid angle. The principal challenge is to design the coils to minimize their obstruction. A solenoid, which is ideal for center of mass collider detectors comes up short in a fixed target program and does not give satisfactory momentum analysis in the forward direction thus requiring a second (costly) forward detector. The closed geometry of a solenoid hampers the addition of detectors at a later date and of course the transmission of low energy particles or electrons through a solenoid coil destroys the resolution of any exterior detectors. A large dipole is only suitable for very forward going particles and has a bad asymmetry in its acceptance for particles which have a momentum component parallel to the magnetic field.

The torus seems to be the best choice that optimizes all the desirable traits of a Large Acceptance Spectrometer. Figure 5 shows a cross section of the LAS Torus.

The field levels of our torus could be achieved by conventional coils, but they would be immense and would consume prodigious amounts of electric power. The essential requirement of at least 80% solid angle coverage including a minimum of 50% at extreme forward angles precludes anything but a compact superconducting design. The basic design concept is a six coil torus utilizing an intrinsically stable epoxy-free design. A preliminary conductor selection indicates that a 10 kA aluminum stabilized design with indirect cooling will provide for conservative quench performance. The necessity for ready access to the particle detectors necessitates a very complex insulating vacuum vessel design.

General Purpose Spectrometer (GPS)

The Hall C physics program requires a flexible environment in which to perform experiments rather than a dedicated fixed facility. Figure 5 shows a conceptual view of the Hall C Experimental Facility. We have selected a general purpose electron spectrometer to meet these needs. (See Figure 7.) This device will use some identical components from Hall A and at least "same technology" magnets for others. An additional feature of the design is its capability of reaching 6 GeV/c momentum. The companion device shown in Figure 8 is an eight gap "Toroidal" spectrometer that through the use of iron wedges to homogenize the field provides a uniform analysis field.<sup>8,9</sup> The superconducting coil design is a natural extension of the Hall A cryostable dipole coil design. This spectrometer uses a beam crossing optics design and has its eight foci located around the beam and down stream.<sup>9</sup>

This device can be used to perform the parity violation experiment in which case the primary electron beam is sent through the axis of the device and special high rate non-tracking detectors are used. The spectrometer can also be used as a short length kaon spectrometer for hypernuclear physics. It can be used as a conventional spectrometer with large acceptance and because of its symmetry is ideally suited to doing out of plane scattering experiments.

Experimental Area Cryogenic System

The three experimental halls at CEBAF will be serviced by a single large 1800 W refrigerator. Transfer lines will distribute helium and nitrogen to each of the halls. The movable spectrometers will have a local distribution transfer line that will ride with the spectrometers and be connected via a flexible section to the transfer line from the End Station Refrigerator (ESR). The ESR in turn is connected to the CEBAF Central Helium Liquifier (CHL) which has been previously described.<sup>11</sup> The ESR will be capable of operating as a stand alone refrigerator initially and as a satellite system if extra capacity is required. The projected heat load distribution is listed in Table III. A further benefit of the transfer line and gas return to the CHL is the centralization of inventory management during warmup and cooldown where large quantities of

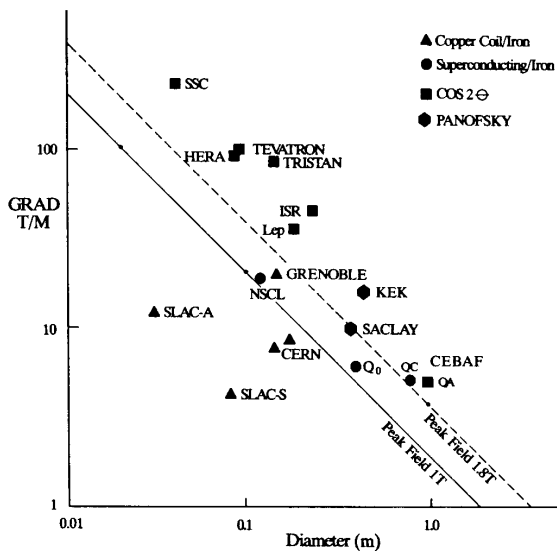

Figure 3: Graph of Quadrupoles  
helium need to be moved from magnets to storage and back. The ESR has been made available to CEBAF from another lab as surplus and the CHL is presently under fabrication.

#### Conclusion

CEBAF has selected superconducting magnets to solve some intriguing problems in experimental Nuclear Physics. These magnets along with our superconducting RF cavities<sup>1,2</sup> are at the forefront of conventional superconductivity. It is our intention to procure these magnets from industry. CEBAF will begin releasing Requests for Proposal in FY 89 and we expect to award contracts in FY 90 for these magnets. We believe our base of industrial support is substantial given the high level of participation in our Industrial Liaison Program (ILP). This program has resulted in substantial and sustained interaction between industry and CEBAF technical and management people. Our industrial colleagues have contributed immensely to our effort and I wish to thank them for their help in promoting the success of the CEBAF superconducting magnets.

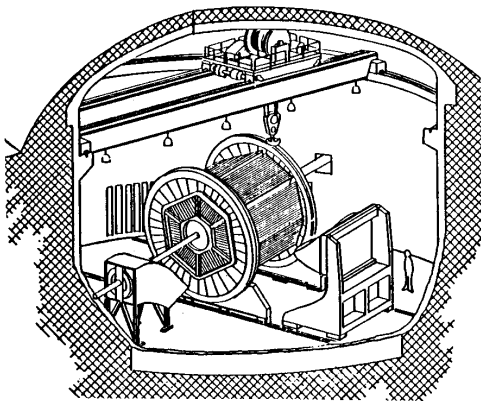

Figure 4: LAS/Hall B 100' Diam.

Table III

Cryogenic Heat Load			
	Calculated Load	Capacity	Lead Flow
Hall A			
Electron Spectrometer	65 W	140 W	72 l/hr
Hadron Spectrometer	45 W	100 W	44 l/hr
Hall B			
Toroid	35 W	100 W	40 l/hr
Hall C			
Electron Spectrometer	45 W	100 W	40 l/hr
Hadron Torus	58 W	160 W	16 l/hr
Transfer Lines	<u>30 W</u>	<u>100 W</u>	<u>N/A</u>
System Capacity	<u>280 W</u>	<u>700 W</u>	and <u>212 l/hr</u>
Refrigerator Capacity		1800 W	

#### REFERENCES

- [1] C. Leemann, "The CEBAF Superconducting Accelerator", Linac '86, SLAC 303, p. 194.
- [2] P. Brindza, et. al., "Superconducting Magnets for CEBAF", IEEE Transactions on Magnetics, Vol. 24, No. 2, pp. 1264-1267, March 1988.
- [3] P. Brindza and J. Mougey, Proceedings of the Spectrometer Magnet Workshop, 1986, CEBAF Publication.
- [4] J. Mougey, "HRS Spectrometer Design", CEBAF Publication, RPAC 1987.
- [5] J. Mougey, Argonne Spectrometer Magnet Conference Proceedings, 1981.
- [6] J. Alcorn, CEBAF Internal Document.
- [7] B. Mecking, "LAS Design", CEBAF Publication, RPAC 1987.
- [8] R. Laszewski, University of Illinois, Private Communication.
- [9] T. Hunter, CEBAF Private Communication
- [10] Mike Finn, William and Mary University, Private Communication.
- [11] P. Brindza, et. al., "CEBAF's Cryogenic System", Advances in Cryogenic Engineering, New York: Plenum Pres, 1987, Vol. 33, p. 623.
- [12] G. Biallas, P. Brindza, C. Rode, "The CEBAF Superconducting Accelerator Cryomodule", IEEE Transactions on Magnetics, Vol. 23, No. 2, pp. 615-618, 1987.

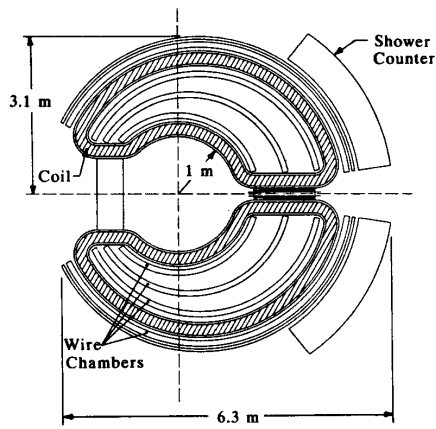

Figure 5: LAS - Torus

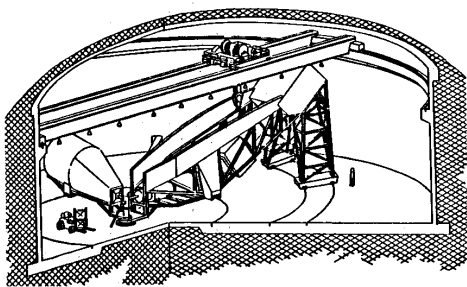

Figure 6: Hall C 150' Diam.

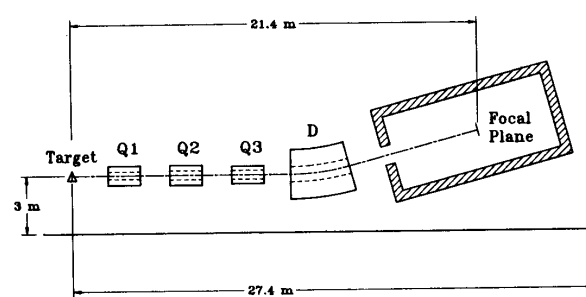

Figure 7: Electron Spectrometer - Hall C

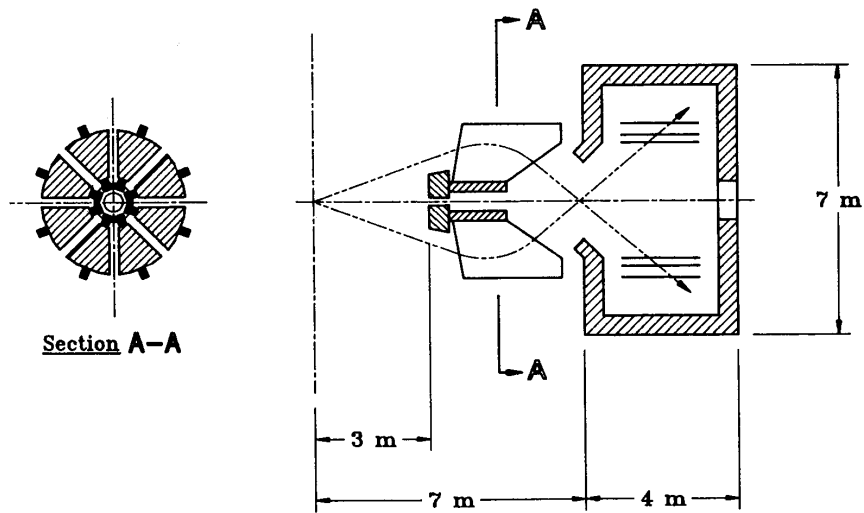

Figure 8: Iron Toroid