

Commissioning the Superconducting Magnets for the High Momentum Spectrometer (HMS) at TJNAF

P. D. Brindza, M. J. Fowler, R. T. Wines, S. R. Lassiter*

Thomas Jefferson National Accelerator Facility
12000 Jefferson Avenue, Newport News, VA 23606

S. R. Milward, S. Pearmain, J. Schouten
OXFORD Instruments Ltd.
Osney Mead, Oxford OC2 ODX England

N. Oda, K. Tamura
Japan Steel Works Ltd.
Muroran, Hokkaido, Japan

F. Ramsauer, S. Wenger, P. Bogensberger
ELIN EA, Magnetecnik, Weiz, Austria

H. Sammer, H. Dermoetz
ATF, Johaneaum Research, Graz, Austria

Abstract –The High Momentum Spectrometer (HMS) became operational in June 1994 and is now in routine use as a nuclear physics spectrometer in Hall C at TJNAF. The commissioning including installation, cooldown, initial operation, testing and acceptance of the SC Quadrupoles and SC Dipole of the HMS will be discussed. Results of measurements performed on the magnets will be presented. The loss of a Dipole current lead, failure analysis and the repairs will be discussed. A brief discussion of the Hall C SC magnet cryogenics will be included.

I. INTRODUCTION

The HMS has been in continuous operation for Nuclear Physics at TJNAF since June 1994. The final magnet delivery was on May 15, 1994 and thus commissioning of the spectrometer occurred during and between running for experiments. Three experiments have been completed to date and preliminary results have been released. The HMS was designed as a 7.5 GeV/C focusing spectrometer primarily to detect electrons in coincidence with other particles in a companion normal conducting spectrometer. The HMS SC magnets are mounted together with their power supplies and control systems on a rotating and self leveling carriage.

The HMS is located in Hall C at TJNAF which is a radiation area necessitating remote control of the magnets and spectrometer rotation. The spectrometer can be positioned remotely to an accuracy of 0.01 degree in azimuth. Leveling has been achieved by leveling the rail, leveling the spectrometer, and periodically verifying that the Hall has not settled or tilted. Hall C has remained level to +/-1 mm as installed for four years. All magnet functions except resetting the Quadrupole energy dump switches can be performed from the Hall C counting house. The magnets are routinely operated by the scientists while performing experiments with magnet experts available on call for problem resolution. A subset of cryogenic valve controls can be accessed by modem

from very distant locations for rapid response to cryogenic or refrigerator problems. This quick response is needed because the HMS was cooled by the same helium refrigerator that cools the SC linac and problems in Hall C could effect accelerator operations. Currently Hall C is cooled by the same refrigerator that cools Hall B and Hall A with similar consequences for unchecked problems.

II. SC MAGNET ACQUISITION

The magnets for the HMS were purchased from industry by fixed-price competitively awarded contracts. The scope of work was for complete turnkey magnet systems including the controls, power supply, quench protection and on site startup and commissioning. Preliminary designs and specifications were developed at TJNAF prior to bidding and award. The manufacturers were allowed maximum flexibility in design and considerable innovation resulted. The design and fabrication of these magnets was planned for 2 years from start to delivery. This was an aggressive schedule that required excellent communication and cooperation between TJNAF and magnet builders. The HMS Dipole which was built by ELIN Energieanwendung of Austria was delivered on schedule. The three Quadrupoles which were built by Oxford Instruments in Great Britain were delivered over a six month period with final delivery coming about 3 months late. The steel for the HMS Dipole came from Japan Steel works and was delivered on time. The magnets were cooled down and operated for the first time at TJNAF. This meant that most manufacturers' trouble shooting had to take place in the field. This has several benefits including making tight schedules realistic and trouble shooting under realistic conditions. The obvious disadvantages of higher cost and a distant manufacturers' support system had to be overcome by careful scheduling and planning. The concurrent experimental use and commissioning activities as well as the distant manufacturers lead to a protracted contract closeout which did not occur until two years after final delivery. Table I

Received August 20, 1996

Work supported by Department of Energy contract #DE-AC05-84ER-40150 and DE-AC03-76SF00515

contains a summary of all pertinent magnet properties and Table II contains a summary of major contract information.

TABLE I

Magnet	Q1	Q2/Q3	Dipole
Pole-Pole Gap/Bore n	0.50	0.70	0.42
Useful Aperture m	0.40	0.60	0.40
Max. Current Amps	1012	1023	3000
Total Number of turns	177	345	312
Max. Field or Gradient	7.138 T/m	6.320 T/m	2.100 T
Delta B/B %	<1%	<1%	0.10%
Effective Field Length m	1.892	2.184	5.256
Max. Inductance Henries	0.605	3.534	2.200
Stored Energy Mega-joules	0.301	1.463	9.900

TABLE II

	Dipole Coil	Dipole Steel	Quads
Award Date	July '91	July '91	Feb. '92
Contract Duration	24 Months	18 Months	24 Months
Actual Delivery	24 Months	17 Months	27 Months
Original Contract Cost	2.17M\$	1.77 M\$	3.07M\$
Final Cost at Closeout	2.09 M\$	1.77 M\$	3.04 M\$

III. HMS DIPOLE COMMISSIONING ACTIVITIES

The Dipole arrived in May 1993 and was installed in June. The first cooldown which took three days was complete on August 14 and first current was achieved on August 15. Apart from the usual problems with wiring and software there were several unexpected problems that were due to the proximity of the control and power supply to the magnet. The following components were susceptible to error at various levels of excitation. The current lead flow meter was a magnetic rotameter and was affected at very low fields and was useless until an iron box was fabricated for it. Above 2000 Amps the stray field adjacent to the Dipole reached 1 K Gauss levels. The computer video display lost color and then faded completely. The power supply current transducers stopped compensating at 2300 Amps and shut the power supply down. Fast discharges at 2000 Amps damaged the computer hard disc. The control and power supply were relocated to a less magnetic environment and on September 24 Friday, the HMS Dipole reached 3000 Amps, the design current without incident.

On Saturday, October 2, 1993 during a test of the power supply by the manufacturer a current lead failed at 3000 Amps. A determination was made that the failure was due to uneven coolant distribution between the leads permitting the right lead to cool and the left lead to get hotter and melt. There was no analog overvoltage protection for the current leads and the software protection was not working. Apart from the damaged current lead and some incidental damage to electronics, the Dipole had an internal short to ground and shorted turns. The short to ground was 0.5 Ohms and there appeared to be several shorted turns as determined by inductance measurements. The magnet was partially cut open to access the damaged lead and in other locations in an attempt to locate the short. After visual and borescopic

inspection failed to locate the short it was decided to simply replace the current leads and test the magnet.

A progressive test procedure was devised to determine the actual condition of the magnet and to permit continued use of the magnet without a costly and time consuming removal and complete repair. The Dipole was first operated at 300 Amps at room temperature to test the integrity of the copper stabilizer. The coil was cooled to 80 K and was taken up to 300 Amps to verify that the copper could handle the full current at 4K if the coil went normal. The 80K test was extremely successful as the shorted turns disappeared during these tests in addition to confirming that the copper stabilizer was continuous and verified that the coil would still be cryostable i.e., that the copper was intact. The next test involved operating the coil at 8 K to determine if the superconductor was intact. These conditions were chosen so that the SC would have to be intact and that the coil would not be cryostable so that a quench would propagate and be easily seen. The coil was operated at 8 K and 1500 Amps with no evidence of normal zone generation. This proved that all 6 superconducting strands were undamaged. The coil was cooled to 4.2 K and operated again at 1500 Amps with a fast discharge from 1500 Amps. The Dipole was operated for 24 hours at 1500 Amps to certify it for continuous use. This proved that the coil could operate as designed and that the voltage from a discharge would not cause internal breakdown.

The coil properties remained constant throughout these tests except for the "burnout" of the shorted turns. The short to ground actually increased in resistance to 3 Ohms at 4 K. This evidence tends to confirm the theory that the shorts were due to debris from the melted current lead that had fallen into the coil rather than a short across the g-10 insulation or a partial meltdown of the conductor. The increase in resistance is characteristic of a copper oxide-like material that could have formed when the current lead melted. The burnout of the shorted turns is also indicative of the shorts being due to foreign matter. Finally the surviving data record from the October 2 incident is completely consistent with a fast discharge through the dump circuit. That, plus the absence of other damage, tends to confirm that 90% of the magnet's stored energy was deposited in the energy dump and the remaining 1 MJoule went into melting approximately 1 Kg of current lead. This material was eventually recovered from the insulating vacuum. A small quantity of very small heavily oxidized copper "shot" was found in the bottom of the helium reservoir when it was opened. It is this material that was the likely cause of the shorts. The magnet system was significantly upgraded as a result of this incident. The system of a single flow control valve and a single flow meter has been replaced with individual control and measurement of each current lead. The original 3000 Amp leads were replaced with 5000 Amp current leads to provide greater tolerance to coolant problems at the expense of overall cryogenic efficiency. A second commercial quench detector has been added to the system incorporating current lead overvoltage detection. The maximum operating current interlocks have been set at 1500

Amps corresponding to 4.5 GeV/c to prevent accidental operation above presently required levels.

IV. QUADRUPOLE COMMISSIONING

The commissioning of the HMS Quads was less exciting than the Dipole. The first Quad delivered was of the larger size Q2/Q3 variety and it was installed on a test stand off the HMS carriage to permit the rotating coil field measurements without interfering with other work. The 10 day cooldown went without incident and after a lengthy period of control system shakedown the measurements started. The second Quad arrived while the mapping was in progress and therefore the second Quad was dubbed Q2 and installed on the carriage. The mapper was adapted to allow an in-place measurement and Q2 was commissioned and mapped on the carriage. Q1 arrived on May 15, 1994 and was installed, purified and connected to the cryosystem for cooldown start in less than 24 hours. The first beam into Hall C occurred on June 1, 1994 and the HMS was up and running to produce a carbon target spectrum from the first beam. The field mapping for Q1 was performed during a shutdown in place. The details and results of the Quad measurements are presented in this conference by Lassiter et al.[12].

The HMS Quadrupoles required numerous wiring and software improvements as might be expected with few notable problems. The N=6 correction coil in the Q3 Quadrupole was found to be open-circuited after delivery. This multipole was abandoned rather than attempt a surgical recovery as it was unlikely to be immediately beneficial to the spectrometer. Q3 was plagued for a few days with a shorted main coil to ground. This short disappeared during measurements to characterize the problem. It has not reappeared in over one year. One can speculate that the open N=6 coil and the intermittent short may be related. Finally it was found that all quench detectors were insensitive to open sense wires and appropriate measures had to be taken to insure the integrity of these systems.

V. HMS SC MAGNET CRYOGENICS

The cryogenic system for the HMS magnets consists of three systems. The refrigeration system supplied by the TJNAF cryogenics group, the distribution system supplied by TJNAF Hall C, and the control and reservoir in each magnet. The cryo system supplies supercritical helium gas for operation at 4.2K and variable temperature helium for cooldown is made from LN2 and a heat exchanger in Hall C. The control of cooldown flow and temperature as well as the maintenance of LHe and LN2 reservoir levels is performed by each magnets' control system. The four SC magnets have nearly identical cryogenics and thus operation is very similar. The system has worked very well and the hardware has been extremely reliable. The measured heat loads of the Quads are 11 +/-1 Watts and the Dipole is 60 +/-10 Watts. The cryo system has each magnet in parallel so that it is possible to warm or cool or operate each magnet independently. This allows one magnet to be warmed for servicing while the others are maintained at operating conditions. Presently only

the Dipole requires an annual warm-up to 80K for the purpose of pumping the insulating vacuum. This is due to the gas load accumulation from two very small leaks. There is helium leak of 4×10^{-9} liter and a nitrogen leak of 5×10^{-8} liter. The helium leak is so small that it takes one year of cryosorption to saturate the magnet's interior surface and thus requires an annual pumpout.

VI. RADIATION DOSE EFFECTS ON HMS ELECTRONICS

The HMS control system and power supplies are exposed to the radiation field present in Hall C during beam on operations. The design lifetime absorbed dose was 1×10^{-5} rads. The measured dose rates near the control racks are 0.5 rads for gamma and 2 rads for thermal neutrons. These dose rates are consistent with estimates for backgrounds and are comfortably below exposures required to damage electronics. Nevertheless there have been some irritating problems. These low doses are capable of corrupting the content of various memory chips. Ordinary RAM chips appear to be the most sensitive with the more sophisticated higher density RAM being more sensitive than low density. We have observed the corruption of some EPROMS as well. These effects were proven to be well correlated with the product of beam intensity and target thickness. The simple expedient of relocating the sensitive PC's to a shielded location has raised the reliability to the level where computer hangs occur on the average less than once per day per PC. Other systems such as PLC's with 8088-era processors seem to be able to operate for several days before hangs occur. Signal conditioners, smart gauges, and the processors that control the Danfysik power supplies seem to be immune. The symptoms of radiation damage seem to be a partial or complete corruption of the software only resulting in a system stoppage and subsequent magnet shutdown due to the watchdog interlocks. A simple reboot restores the system to operation. There is as yet little or no evidence of permanent damage to electronics. Numerous electronic components have been replaced anyway as the frequency of faults increases, as a precaution and to perhaps enhance reliability.

VII. CONCLUSIONS, CONGRATULATIONS AND IN MEMORIAM

The HMS spectrometer has been operating now for two years for nuclear research and has completed three experiments. Currently it is the mainstay of TJNAF's experimental program but it will be joined this year by the HRS spectrometers in HALL A and the CLAS torus early next year. Oxford Instruments, Japan Steel and ELIN were truly TJNAF's partners throughout this venture and they are to be congratulated for their excellent work under tough circumstances. They persevered through the solution of some difficult problems and can be justifiably proud of the excellent spectrometer that should still be doing useful work when our grandchildren are studying Physics. Finally, it is with great personal sorrow that we note the passing of the Magnetecnik group of ELIN. The many fine professional colleagues are now just good friends.

REFERENCES

- [1] CEBAF's Cryogenic System, P. Brindza, W. Chronis, C. Rode, J.P. Kelley, M. Shea. *Adv. in Cryo Eng* Vol. 33, P. 623.
- [2] Conceptual Design Report Basic Experimental Equipment - CEBAF Hall C, April 13, 1990.
- [3] P.D. Brindza et al., "CEBAF Superconducting Spectrometer Design", *IEEE Transaction on Magnets*, Mag. 25, pp. 1897, 1987.
- [4] P.D. Brindza et al., "Superconducting Magnet for CEBAF", *IEEE Transaction on Magnets*, Mag. 24, no. 2 pp. 1264, 1988.
- [5] L.H. Harwood, et al., "A Superconducting Iron-Dominated Quadrupole for CEBAF", *IEEE Transaction on Magnets*, Mag. 25, pp. 1910, 1989.
- [6] S.R. Lassiter, et al., "Large Aperture Superconducting Cryostable Quadrupoles for CEBAF's High Momentum Spectrometer", *IEEE Transaction on Magnets*, Vol. 27, No. 2, 2288, March 1991.
- [7] S.R. Lassiter et al., "Final design and construction progress for CEBAF's cold iron Quadrupoles", *IEEE Transaction on Applied Superconductivity*, Mag. 3, no. 1 pp. 118, 1993.
- [8] J.A. Miller, P.D. Brindza, M.J. Fowler, W.T. Hunter, S.R. Lassiter, R.R. Thorpe, "Cryostat Design and magnetostatic Analysis of the 6 GeV Superconducting Dipole for the CEBAF High Momentum Spectrometer", *IEEE Transactions on Magnetics*, Vol. 27, No. 2, pp. 2292-2295, March 1991.
- [9] P. Bogensberger, R.K. Maix, F. Ramsauer, H. Kofler, K. Piswanger, P.D. Brindza, "Design and Manufacture of the Dipole Coil for the CEBAF High Momentum Spectrometer", Paper presented at ASC 1992 Chicago.
- [10] H. Kofler, G. Krainz, J. Sammer, R.K. Maix, F. Ramsauer, P. Brindza, "Concept of Quench Protection and Automatic Control for the HMS Dipole Magnet System for CEBAF", *IEEE Transactions on Applied Superconductivity*, Vol. 3, No. 1, March 1993.
- [11] R. Wines, P. Brindza, M. Fowler, S. Lassiter, F. Baumann, P. Bogensberger, R.K. Maix, F. Ramsauer, A. Umschaden, "Structural Analysis of the 7.5 GeV Superconducting Dipole for the CEBAF High Momentum Spectrometer", *IEEE Transactions on Applied Superconductivity*, Vol. 3, No. 1, March 1993.
- [12] S. Lassiter, P. Brindza, S. Wood "Magnetic Measurements of Large Aperture Superconducting Quadrupole Magnets for TJNAP's High Momentum Spectrometer", *IEEE Transactions on Applied Superconductivity*, LKC-2.

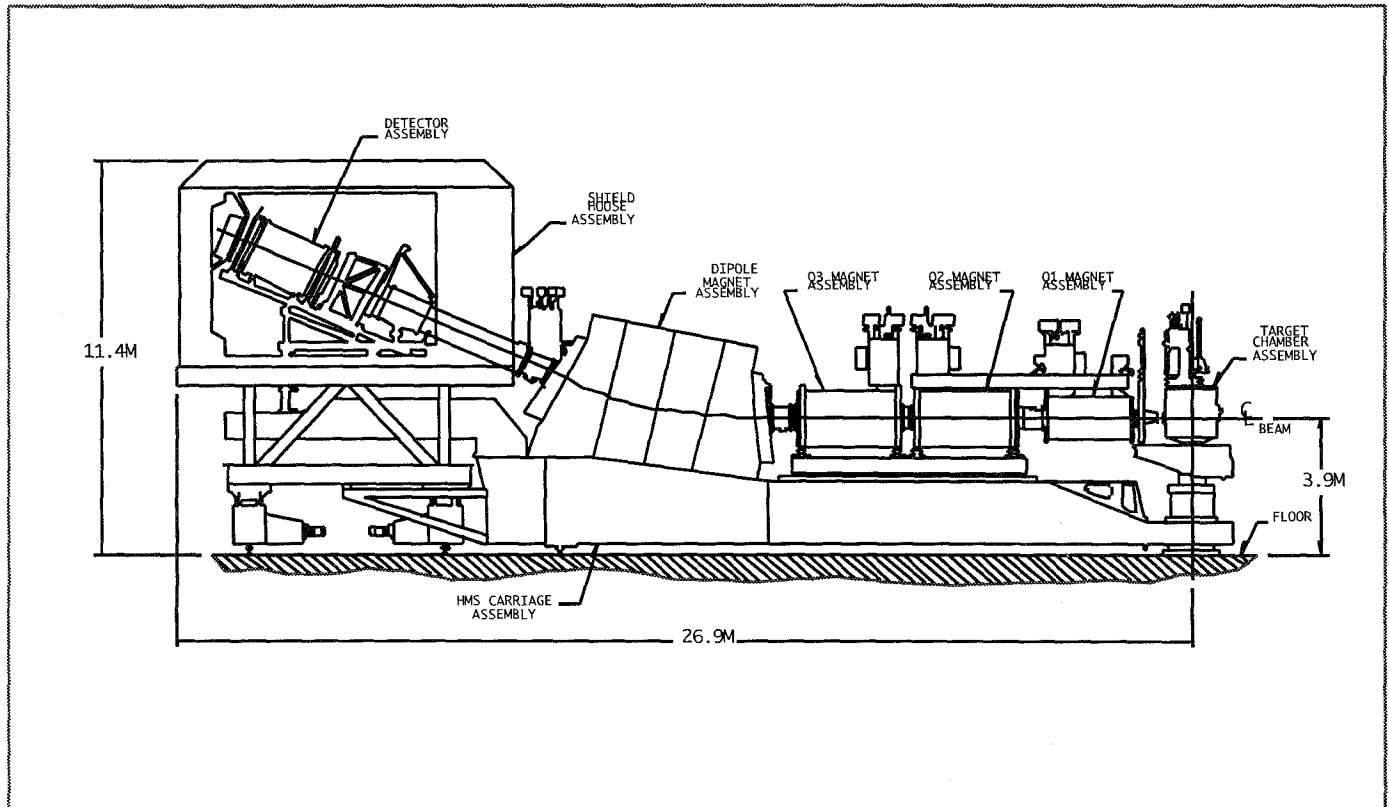

Figure 1: HMS Superconducting Spectrometer