

The G0 Target Load-Lock

- Think of it as an insurance policy
 - A target problem \Rightarrow 6 weeks minimum down time (3 weeks to warm, 3 weeks to cool) not including target repair.
 - The run would have to be re-scheduled.
 - Paranoid view: re-scheduled may turn into canceled.
- A question for the collaboration: How much should we pay for target-failure insurance?

Load-Lock Design

- There are an infinite number of possible designs.
- We don't have time to investigate them all.
- Two ideas were considered:
 - Constant volume (the original concept)
 - Cryogen delivery difficult – no space for internal lines.
 - Service module probably can't be re-used.
 - Diagnostic girder too far upstream.
 - Variable volume
- In either case, require a valve that fits inside of the Ferris wheel -- which rules out a standard gate valve.

Variable Volume Load-Lock

- Employ “flap” valve to seal off magnet vacuum. This is custom built, but vendors have been identified.
- Service module mounted on a LONG large diameter bellows upstream of valve.
- Service module, bellows, and (removable) girder supported on Z rails.

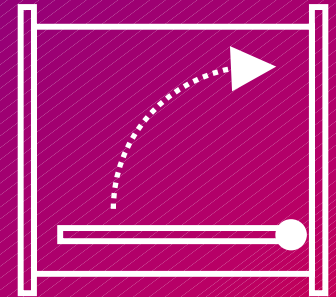

Target in running position (valve open).

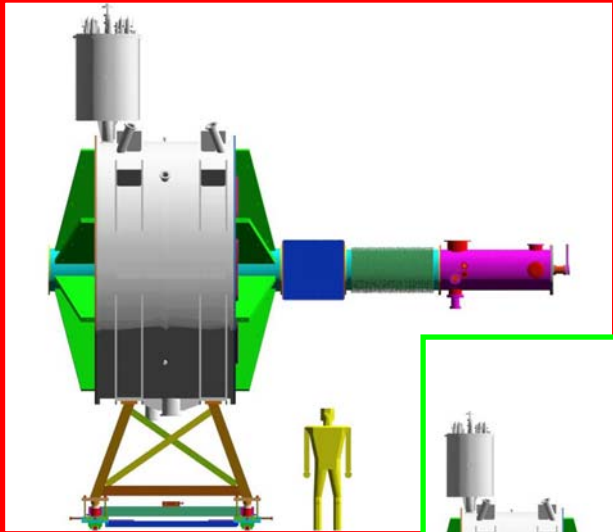

Remove girder, retract target, then close valve.

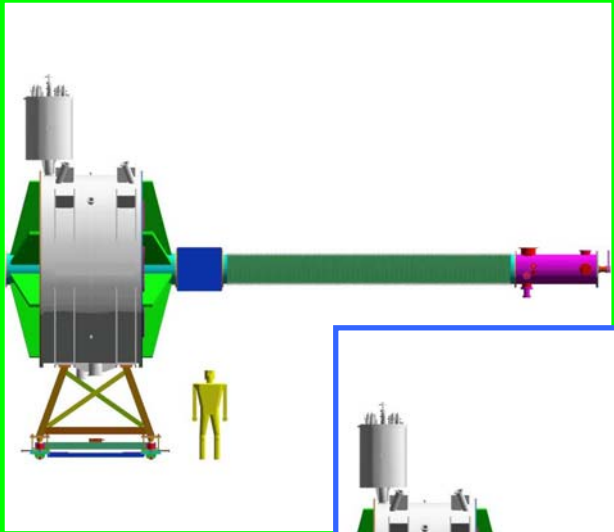

Collapse bellows and service target.

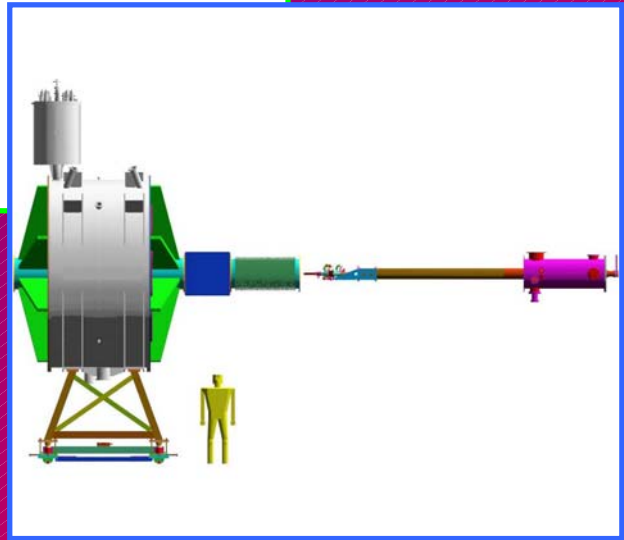

How it works

Load-Lock Bellows

- Typical dimensions:
 - ID: 21.25"
 - OD: 27.25"
 - Stroke/convolution: 0.5"
 - Total stroke: 180" (15')
 - Segmentation: about 5
 - Contracted length: 64"
 - Extended length: 244" (20')
 - Weight: 2261 lbs
- Forces:
 - Air pressure: 7000 lbs.
 - Spring extended: 1405 lbs
 - Spring collapsed: -921 lbs
- RFP due on June 1.

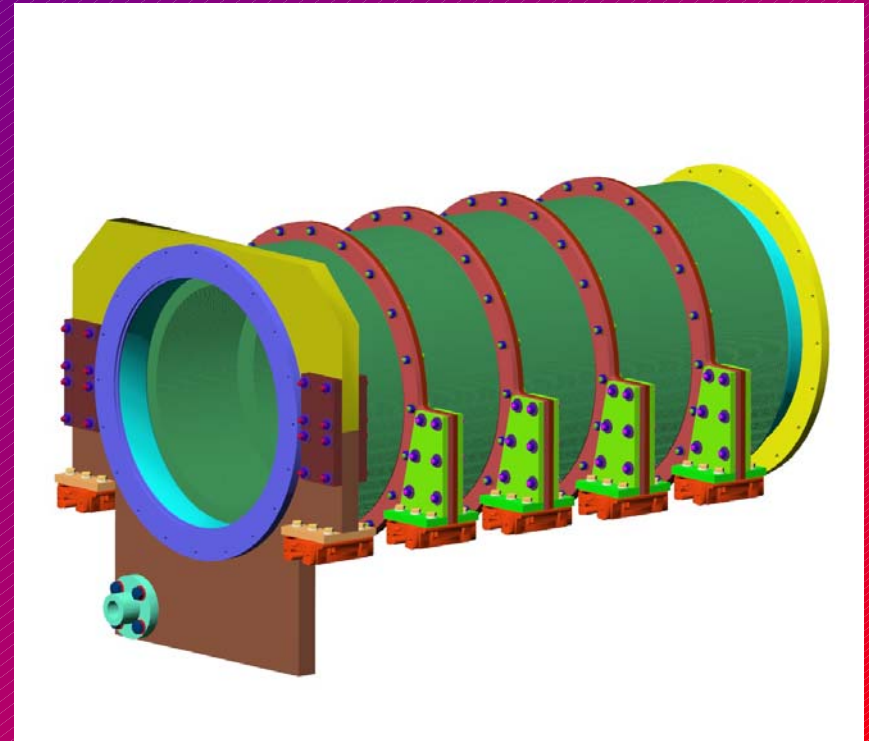

Support of the Load-Lock

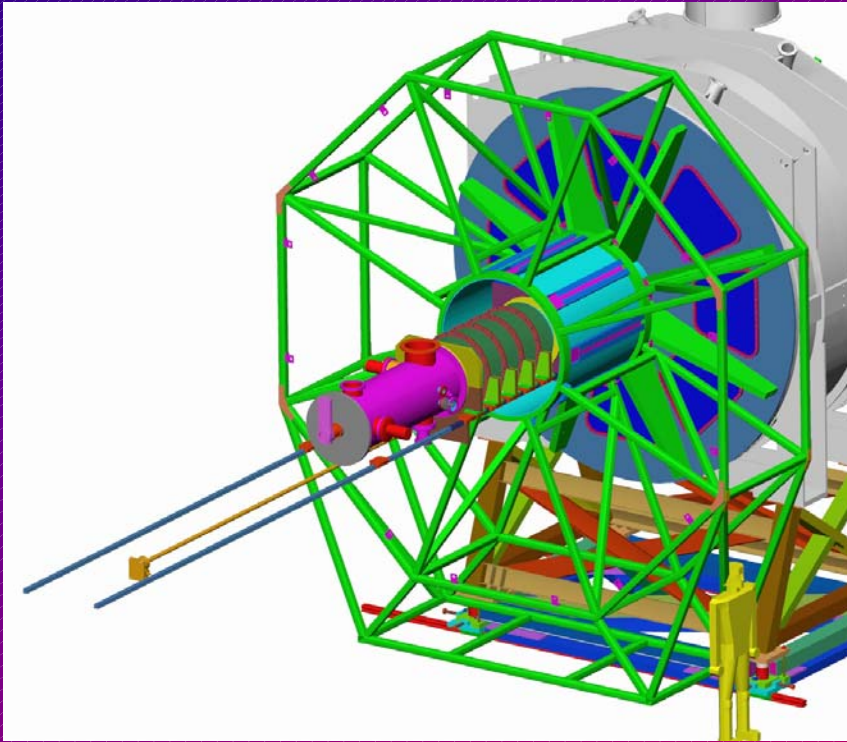

- Support design just starting.
- THK rails support service module, bellows segments, and girder.
- 10 T motorized jack (traveling nut on upstream bellows flange) used to extract target in 15 to 30 min.

Concerns

- Will the target actuators have the precision and force required by the much longer support arm (8' longer: 37" for valve + 64" for bellows)?
- Long horizontal H₂ return line means the location of the liquid surface is not well defined – this can lead to target pressure instability.
- Target no longer rigidly connected to magnet. External alignment must be done with system under vacuum. Will it be reliable? Is vibration a problem?
- What are the space constraints upstream of G⁰ (considering future Hall C configurations such as HKS)?
- Need to think of a way to keep cryo lines clean when target is removed (additional pump/purge port on service module?).
- **Cost**

Schedule

- Make a budget, Exec committee preliminary approval – end of June.
- Final approval – July.
- Order long lead-time parts (valve, bellows) and complete design – end of July.
- Assemble and test (without service module) at UIUC – March-April, 2005.
- Ship to JLab for installation – May 2005