

# Polarized $^3\text{He}$ Target Lab Status

Vincent Sulkosky  
August 15, 2002

- Target Equipment Status
- Water calibrations, Q-curves, and Flux
- EPR fiber coupler and Spectrum analyzer systems
- Cell results from NMR
- Density and Wall thickness

## Target Equipment Status

### New Equipment

- Computer for NMR and EPR systems
- Spectrum Analyzer (SA) with USB port connection
- Gaussmeter probe for field mapping

### Target System Modifications

- Ice cone target ladder design
- Pick-up coils with front flange removed
- Location of Pick-up coils (2.5" upstream)
- EPR coupler mounting design
- EPR RF coil for transverse

## Water Calibrations, Q-curves, and Flux

### Water Calibrations and Q-curves

- Q-curve gain from moving pick-up coils upstream
  - Smaller Q-curve amplitude
  - No change in gain
- Ice cone water calibrations (June and July)

Calibration	06-26-02	07-31-02
Water Cell	Willie's	Poseidon (Mike)
Number of Sweeps	170	400
Preamplifier Gain	100x	50x
Flux (cm <sup>2</sup> )	36.24	29.26
Up Sweep/Pol.	8.4262e+08	3.5876e+08
Down Sweep/Pol.	8.2290e+08	3.5653e+08
Signal/Pol.	8.3276e+08	3.5764e+08
$C_w$ (mV/(amg*%*cm <sup>2</sup> ))	0.07051 ± 0.00191	0.07501 ± 0.00182

### Flux for Ice Cone cells

- Treat cylinder and cone parts separately
- Cone adds a small negative contribution
- Flux model tests

Condition	Coil location	Flux (cm <sup>2</sup> )
Ice cone (34cm)	2.5"	36.24
Standard (34cm)	2.5"	38.15
Standard (40cm)	2.5"	38.11
Standard (40cm)	0.0"	37.67
Standard (12cm)	0.0"	39.15
Standard (6cm)	0.0"	20.25

## EPR Fiber Coupler and SA systems

- One location to monitor both longitudinal and transverse absorption spectrums using SA
- 1 mm diameter fiber for EPR coupler system
- Longitudinal EPR coupler system works fine
- Transverse EPR RF coil added, Transverse works better

- Interference of fibers at Reference cell position fixed

Figure 1: Transverse Fiber interference

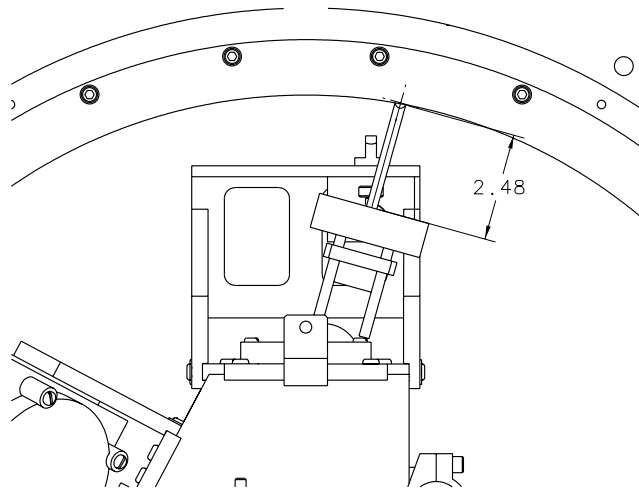

- Effects of couplers on helium and water signals
  - No change in Duke Lifetime  
47.63 hours(In) and 47.48 hours (Out)
  - EPR AFP loss (Needs more work)
  - Magnetic micrometers replaced on couplers

## Cell Results from NMR

- Victor and Prasch:

Cell (Ice Cone)	Victor	Prasch
Oven (°C)	180	190
Lasers	3	3+18W
Flux (cm <sup>2</sup> )	36.46	37.85
T <sub>predicted</sub> (°C)	237.6	236.4
TC density (amg.)	8.08	8.39
Max. NMR signal	5.88	7.25
Calb. constant (%/mV)	4.81	4.46
NMR max. pol.	(28.3 ± 1.4)%	(32.3 ± 1.3)%
Longitudinal gradient (mG/cm)	7.40	7.05
AFP loss (%/sweep)	0.17	0.3
Lifetime (Hours)	25.45	22.92

- Pinocchio optimization tests:

Oven (°C)	170	190	190
Lasers	3	3	3+18W
Flux (cm <sup>2</sup> )	37.33		
T <sub>predicted</sub> (°C)	202.8	227.3	239.9
TC density (amg.)	8.06	8.17	8.24
Max. NMR signal (mV)	5.19 ± 0.10	5.89 ± 0.12	6.62 ± 0.14
Calb. constant (%/mV)	4.43	4.37	4.33
NMR max. pol.	(23.0 ± 0.9)%	(25.7 ± 1.1)%	(28.7 ± 1.2)%

## Density and Wall Thickness

Measurements by Marc McGuigan

### Wall Thickness

- Harry
- Broken Ice cone water cell
- Poseidon

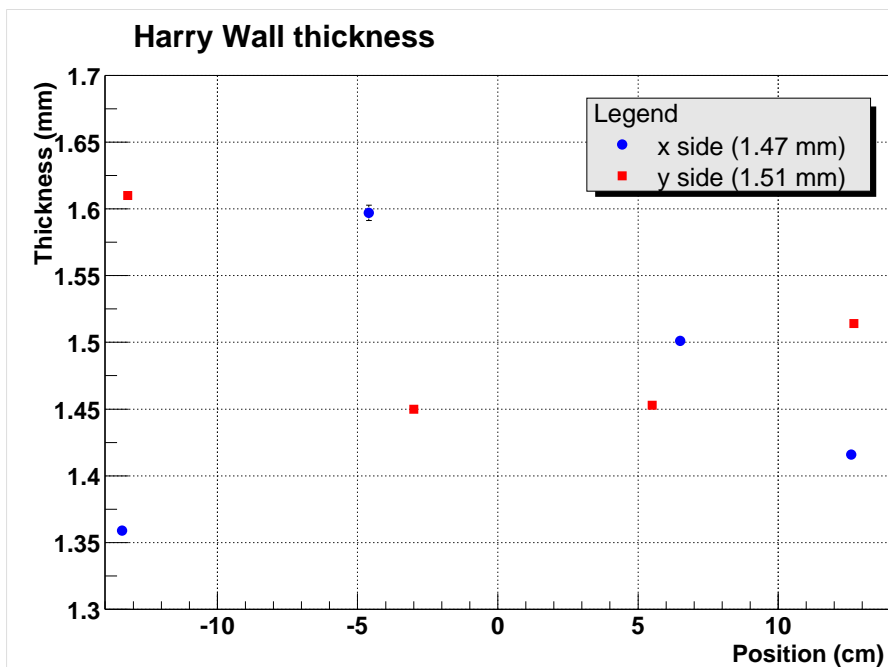

## Density on Patrick

Temperature (°C)	Trial	Density (amg)
75	1	7.10
	2	7.85
	3	7.96
80	1	7.42
	2	8.25
85	1	8.27
	2	8.10
90	1	8.46
	2	8.60
95	1	8.59
	2	8.62
100	1	8.68
	2	8.69

Note: Fill density = 8.54 amg

# Polarized $^3\text{He}$ Target Lab Status

Future Work

August 15, 2002

## Target Work:

- Test cells (Patton, etc.)
- Design field mapping system for 3-axis
- Gradient Compensation (A. Deur, S. Lassiter)
- Final checks on modified flux code
- Move target system to Hall A (1-2 weeks)

## Detector Check Out:

- Calibrate gas cherenkov both arms
- Calibrate shower and pion rejector
- Study PID efficiency