

4

3

2

1

REVISION HISTORY				
ZONE	REV	DESCRIPTION	DATE	APPROVED

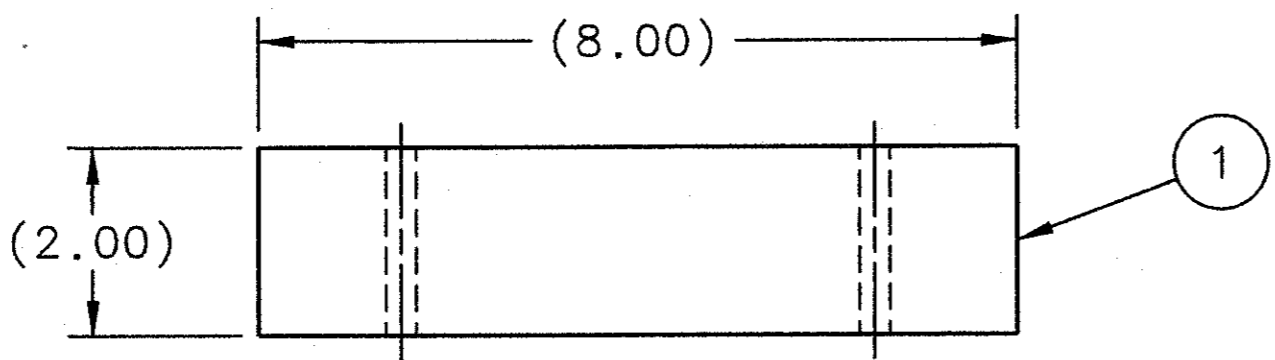
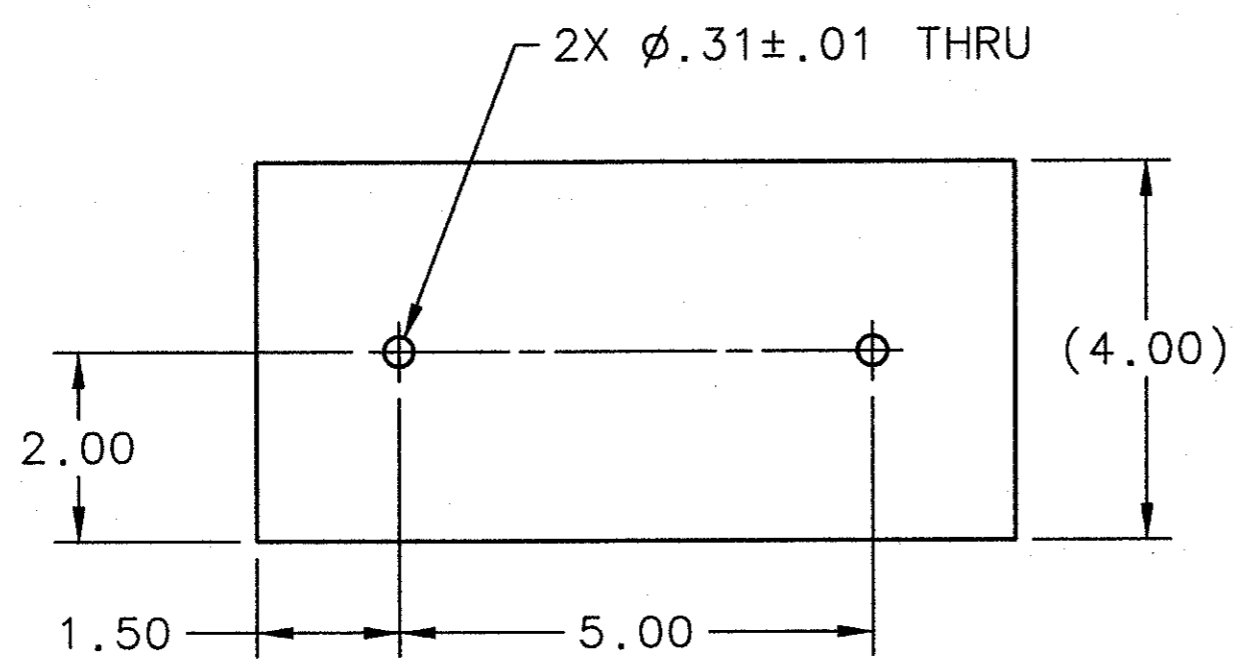
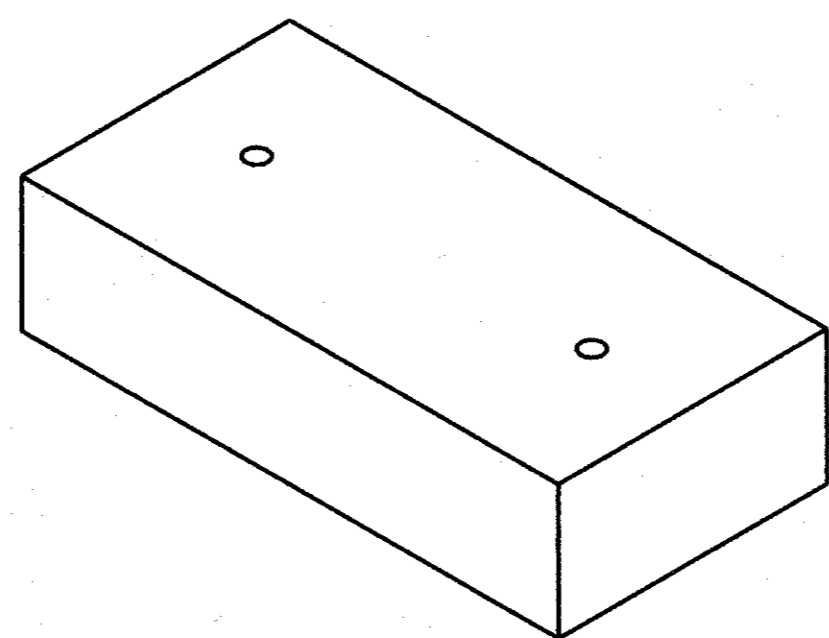

NOTES:

- SUGGESTED SOURCE OR JLAB APPROVED ALTERNATE:
A. McMASTER-CARR www.mcmaster.com

QTY REQD	ITEM NO.	PART OR IDENTIFYING NO.	NOMENCLATURE OR DESCRIPTION	MATERIAL SPECIFICATION	NOTES
1	1	McMASTER-CARR P/N 9033K11	BRICK 2 X 4 X 8	LEAD	

DOCUMENT CONTROL STAMP MATERIAL SEE PARTS LIST FINISH MACHINED SURFACES 125 UNLESS OTHERWISE NOTED DEBURR & BREAK ALL SHARP EDGES DO NOT SCALE DRAWING	DIM & TOL PER ASME Y14.5 UNLESS OTHERWISE SPECIFIED DIMENSIONS ARE IN INCHES TOLERANCES ARE: FRACTIONS DECIMAL ANGLES ± N/A .X ±.1 ±.50* .XX ±.02 .XXX ±.005	TRACKING NO. N/A	United States Department of Energy Jefferson National Accelerator Facility Newport News Virginia
	THIRD ANGLE PROJECTION 	APPROVALS DRAWN R. GETZ CHECKED <i>[Signature]</i> 03/10/11 APPROVED <i>[Signature]</i> 03/10/11 APPROVED <i>[Signature]</i> 08/10/11	DATE 21NOV10

4

3

2

1