

4

3

2

1

REVISION HISTORY				
ZONE	REV	DESCRIPTION	DATE	APPROVED

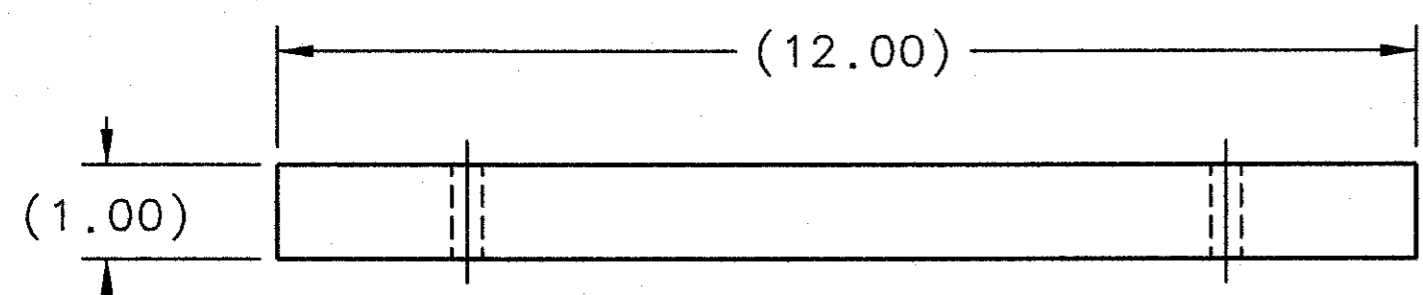
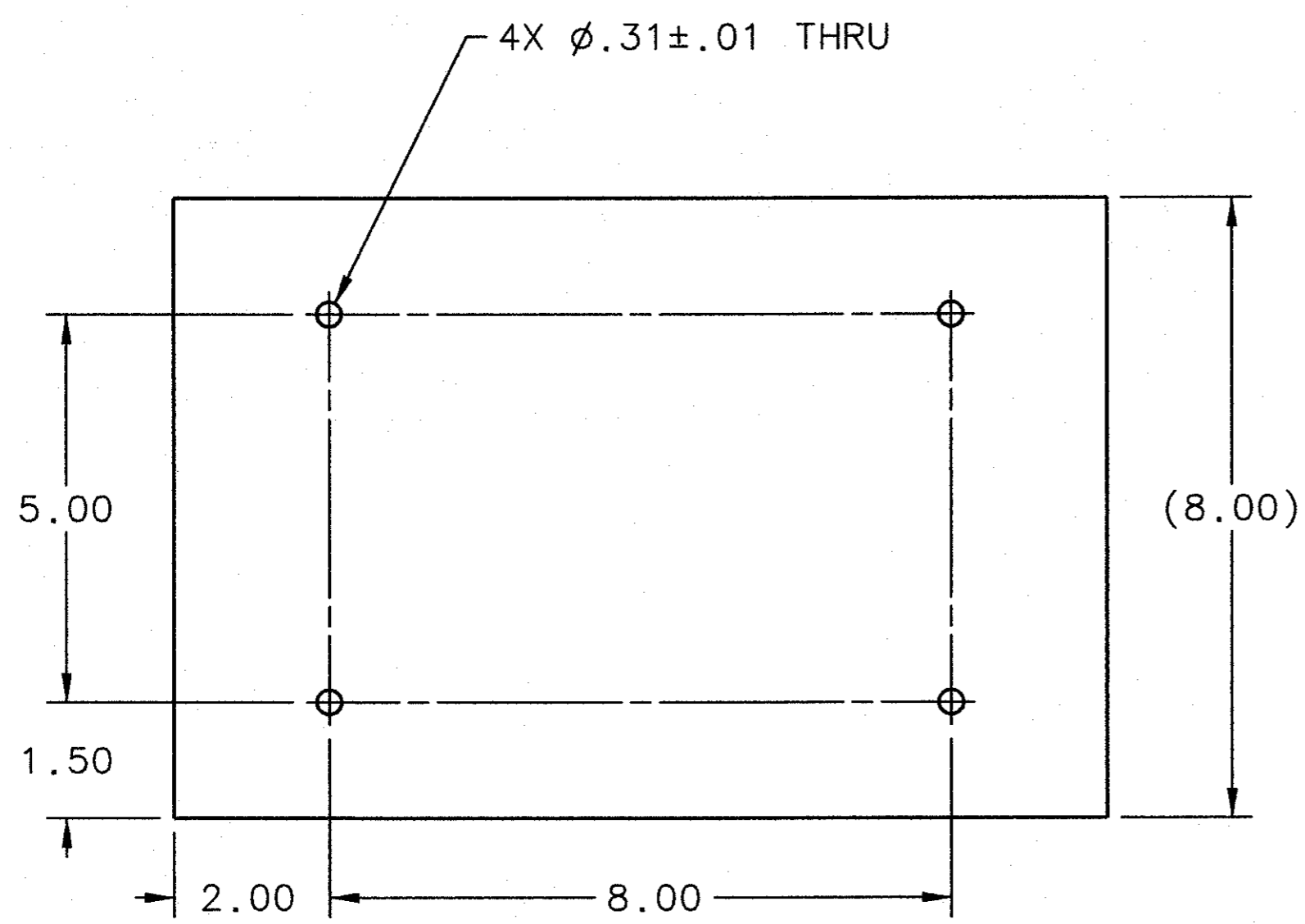
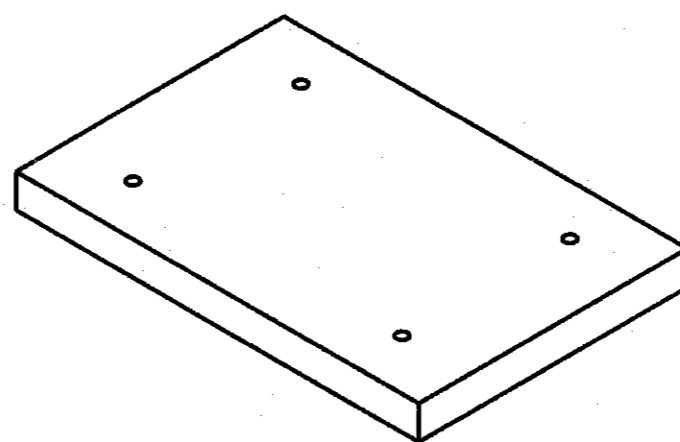

NOTES:

- SUGGESTED SOURCE OR JLAB APPROVED ALTERNATE:
A. McMASTER-CARR www.mcmaster.com

DOCUMENT CONTROL STAMP 	DIM & TOL PER ASME Y14.5 UNLESS OTHERWISE SPECIFIED DIMENSIONS ARE IN INCHES TOLERANCES ARE: FRACTIONS DECIMAL ANGLES ± N/A .X ±.1 ±.50° .XX ±.02 .XXX ±.005	TRACKING NO. N/A		United States Department of Energy Jefferson National Accelerator Facility Newport News Virginia
		APPROVALS	DATE	
MATERIAL 1X8X12 LEAD PLATE	THIRD ANGLE PROJECTION	DRAWN R. GETZ	21NOV10	SIZE DWG. NO. C D00000-06-01-2005
FINISH MACHINED SURFACES 125 UNLESS OTHERWISE NOTED DEBURR & BREAK ALL SHARP EDGES		CHECKED <i>[Signature]</i>	03NOV11	
DO NOT SCALE DRAWING		APPROVED <i>[Signature]</i>	03NOV11	SCALE 1:2 USED ON ASSY NO. D00000-02-01-1001 SHEET 1 OF 1

4

3

2

1