

4

3

2

1

REVISION HISTORY				
ZONE	REV	DESCRIPTION	DATE	APPROVED

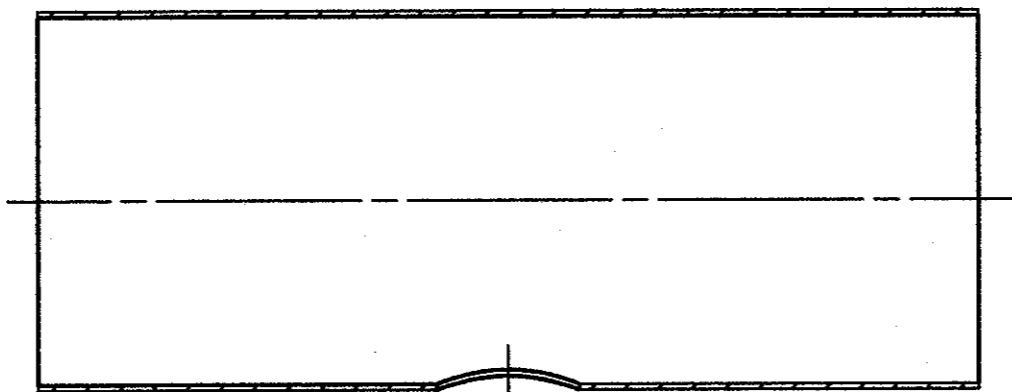

SECTION A-A

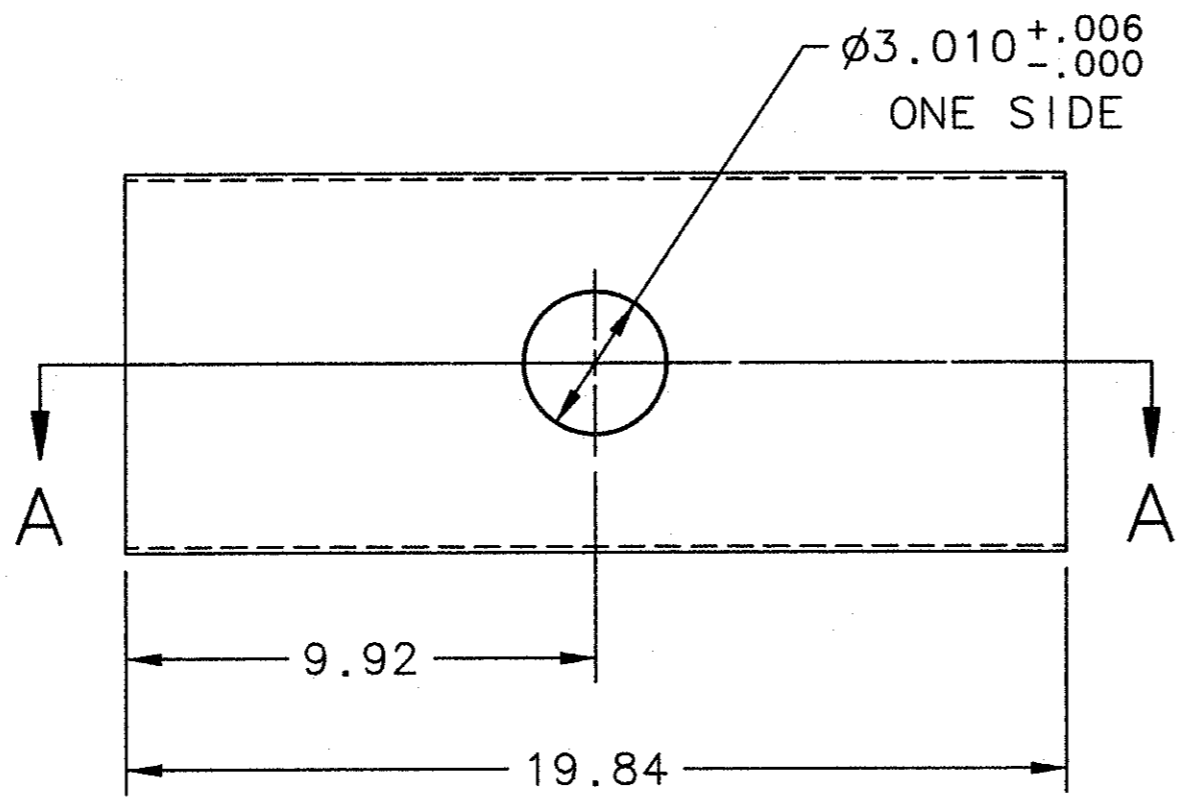
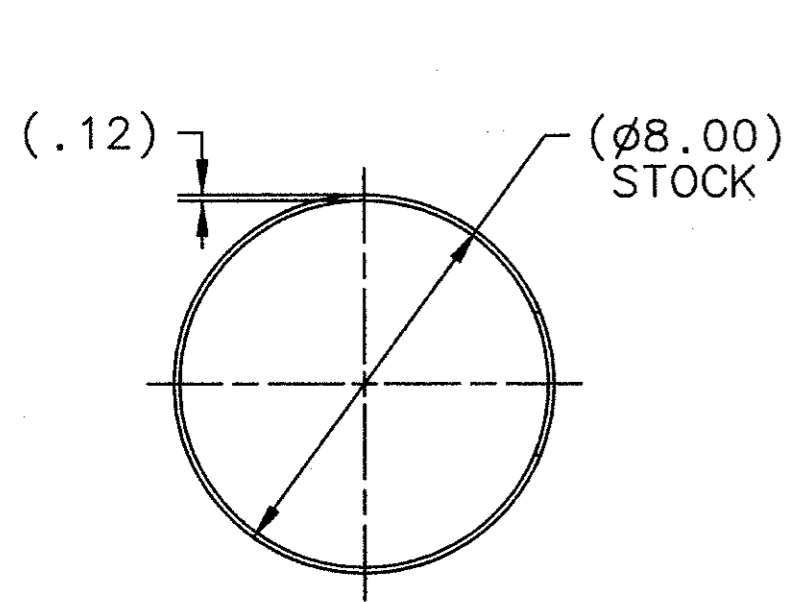

DOCUMENT CONTROL STAMP 	DIM & TOL PER ASME Y14.5 UNLESS OTHERWISE SPECIFIED DIMENSIONS ARE IN INCHES TOLERANCES ARE: FRACTIONS DECIMAL ANGLES ± N/A .X ± .1 ± .50° .XX ± .01 .XXX ± .005	TRACKING NO. N/A		United States Department of Energy Newport News Virginia
		APPROVALS DRAWN R. GETZ CHECKED <i>R. Getz</i> 4 Nov 11 APPROVED <i>R. Getz</i> 4 Nov 11 APPROVED <i>N. S. Miller</i> 08 Nov 11	DATE 5 APR 11	
MATERIAL SS 304, SEAMLESS TUBE 8.00 OD X .12 WALL FINISH MACHINED SURFACES 125 UNLESS OTHERWISE NOTED DEBURR & BREAK ALL SHARP EDGES	THIRD ANGLE PROJECTION 	SIZE C	DWG. NO. D00000-02-01-2043	REV. -
DO NOT SCALE DRAWING		SCALE 1:4	USED ON ASSY NO. D00000-02-01-1007	SHEET 1 OF 1

4

3

2

1