

REVISION HISTORY				
ZONE	REV	DESCRIPTION	DATE	APPROVED

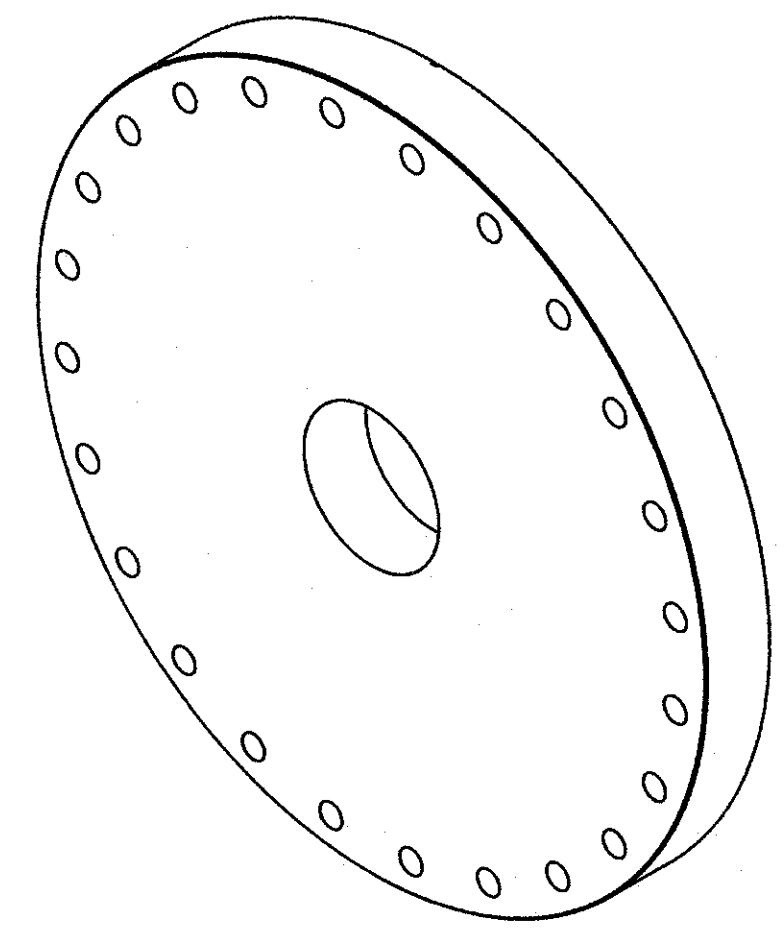

ISOMETRIC VIEW  
SCALE 1:2

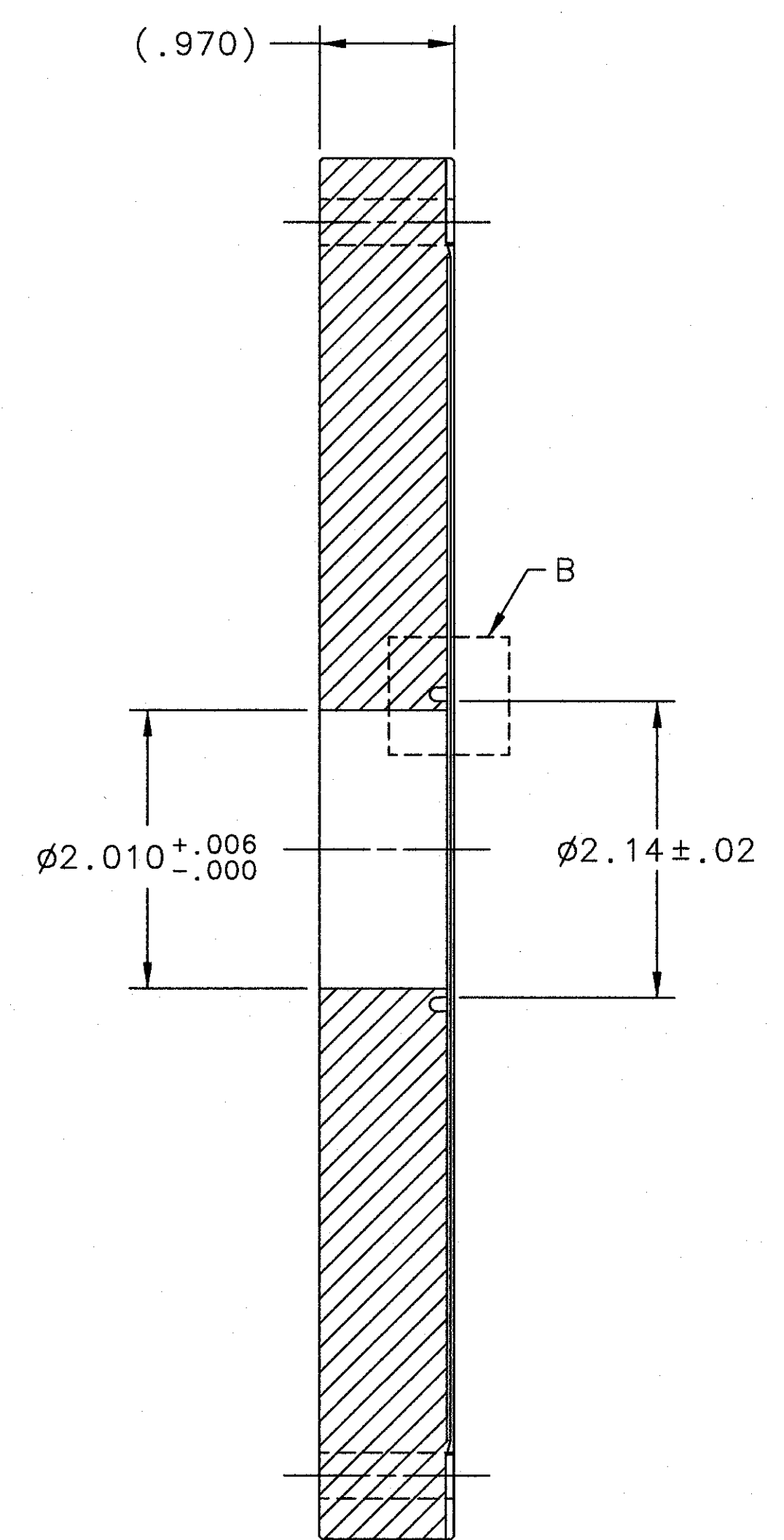
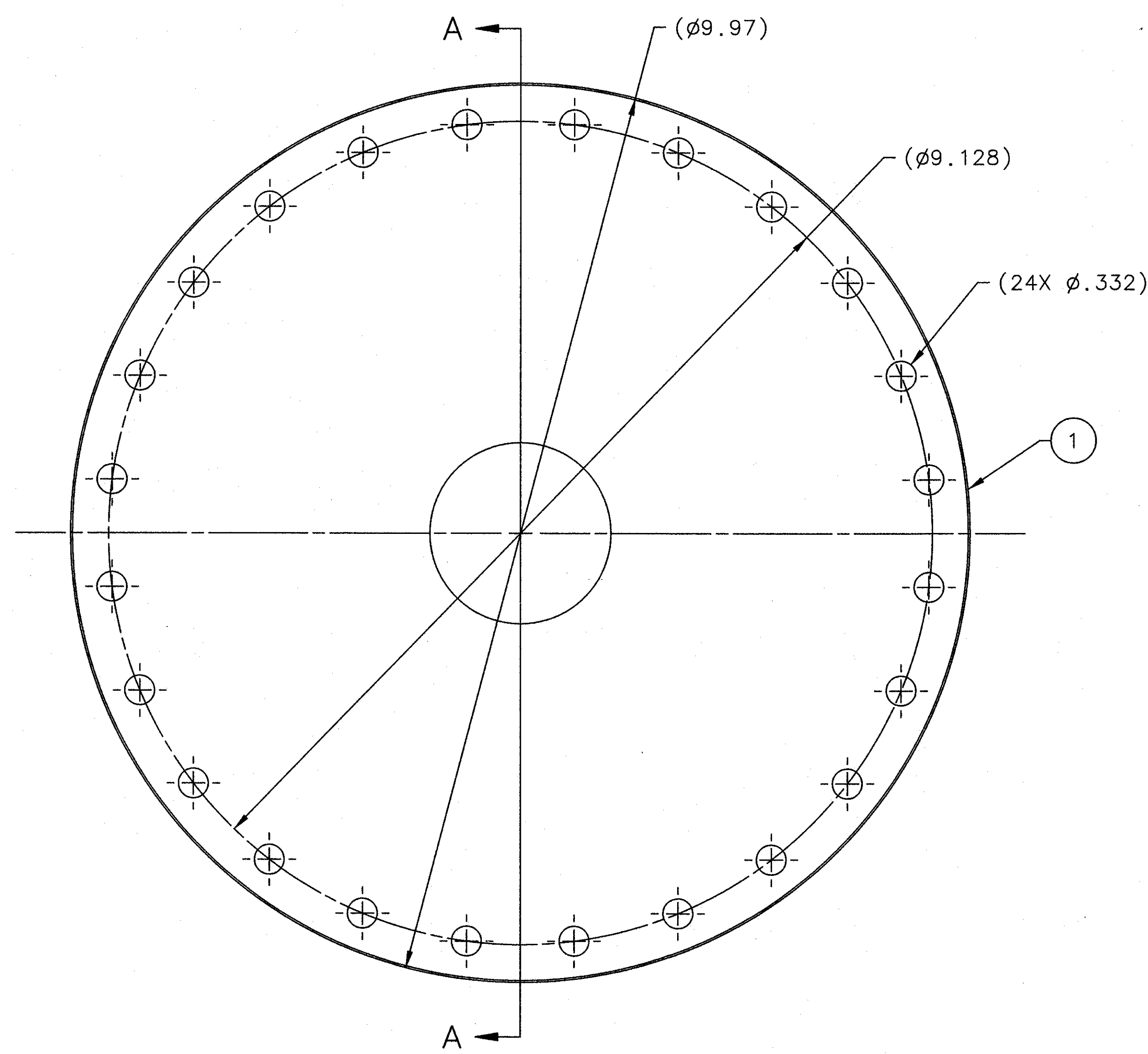
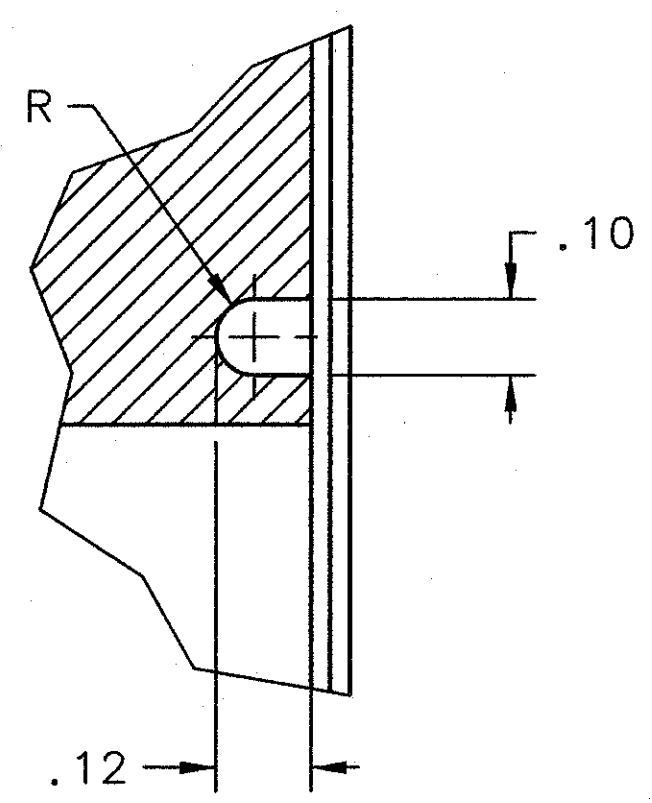

DETAIL B  
SCALE 4:1

SECTION A-A

NOTES:

- THE FOLLOWING JLAB SPECIFICATIONS APPLY:  
 FABRICATION OF UHV EQUIPMENT . . . . . 22631-S-001 REV B  
 CLEANING AND HANDLING OF UHV COMPONENTS . . . 22632-S-001 REV E.
- SUGGESTED SOURCE OR JLAB APPROVED EQUIVALENT:  
 A. MDC VACUUM PROD. (800)443-8817 www.mdcvacuum.com

QTY	ITEM NO.	PART OR IDENTIFYING NO.	NOMENCLATURE OR DESCRIPTION	MATERIAL SPECIFICATION	NOTES
1	1	MDC PART No.110032	DEL-SEAL CF FLANGE 10 OD, CLEARANCE, NR, BLANK	STAINLESS STEEL TYPE 304	2A

DOCUMENT CONTROL STAMP  MATERIAL SEE PARTS LIST FINISH MACHINED SURFACES 125 UNLESS OTHERWISE NOTED DEBURR & BREAK ALL SHARP EDGES DO NOT SCALE DRAWING	DIM & TOL PER ASME Y14.5 - UNLESS OTHERWISE SPECIFIED DIMENSIONS ARE IN INCHES TOLERANCES ARE: FRACTIONS DECIMAL ANGLES ± N/A .X ± .1 ± .50° .XX ± .01 .XXX ± .005	TRACKING NO. N/A	United States Department of Energy Jefferson National Accelerator Facility Newport News Virginia
	THIRD ANGLE PROJECTION 	APPROVALS CHECKED: <i>[Signature]</i> APPROVED: <i>[Signature]</i> DATE: 21NOV08 3 NOV 11 8 NOV 11	HALL D GLUE-X BEAMLIN COLLIMATOR CAVE FLANGE CF 10.0 OD x 2.01 BORE, CL SIZE DWG. NO. D D00000-02-01-2051 SCALE 1:1 USED ON ASSY NO. D00000-02-01-1008 SHEET 1 OF 1