

C31016G-90, C31016G, C31016H Photomultipliers

25.4mm (1-inch) Diameter Ruggedized, 10-Stage End-Window PMTs With High Temperature Na₂KSb Bialkali Photocathodes – for Geophysical Exploration

- Designed for High Temperature Applications (Repeated Cycling) up to 175 °C
- Spectral Range: 250 - 660 nm
- Typical Quantum Efficiency: 17% @ 370 nm
- 91.1 mm (0.75 inches) Minimum Photocathode Diameter
- Highly Stable Copper-Beryllium Dynodes
- For Extreme Environmental Conditions: Designed to Meet MIL-STD-810B

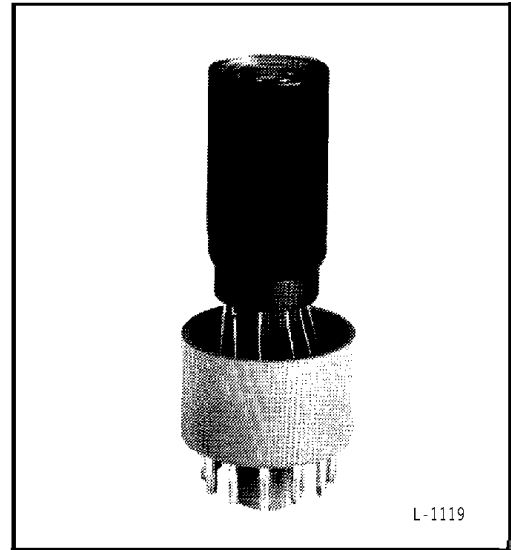

BURLE developmental types C31016G, C31016G, & C31016H are short, ruggedized, 10-stage photomultipliers employing high temperature bialkali (Na₂KSb) photocathodes which permit tube operation in temperature environments as high as 175 °C (C31016H). These types are designed to meet the shock and vibration specifications of MIL-STD-810B.

The C31016 series of tubes are identified as follows:
 C31016G-90 is tested for operation up to 90 °C.
 C31016G is tested for operation up to 150°C.
 C31016H is tested for operation up to 175 °C.

The spectral range of these PMTs extend from about 250 to 660 nanometers. The high temperature performance capability, good time resolution characteristics, and low dark current make the C3106 family extremely useful for gross counting in geophysical exploration applications where cooling requirements must be minimized and in other low light level applications where high ambient temperatures exist.

PLEASE NOTE: Descriptions and parameters in this data sheet refer to the C31016 series of PMTs unless otherwise stated.

General Data

Photocathode Spectral Responsivity..... See Figure 1
 Wavelength of Maximum Response..... 370 nm
 Cathode, Semitransparent..... Sodium-Potassium-Antimony (bialkali)
 Minimum projected area..... 2.9 sq. cm (0.44 sq. in)
 Minimum useful diameter..... 19.1 mm (0.75 in)
 Window Material..... Borosilicate, Corning¹ No. 7056, or Equiv.

Shape..... Plano-Concave
 Index of refraction at 391.4 nm..... 1.50
 Dynodes:
 Substrate..... Copper-Beryllium
 Secondary-emitting surface..... Beryllium-Oxide
 Structure..... Circular-Cage
 Direct Interelectrode Capacitance (approx.):
 Anode to dynode No. 10..... 2.5 pF
 Anode to all other electrodes..... 3.0 pF
 Socket..... BURLE AJ2259
 Net Weight (approx., temporary base removed) 20 g (0.7 oz)

Absolute Maximum Rating²

DC Supply Voltage:
 Between anode and cathode..... 2000 V
 Between anode and dynode No. 10..... 250 V
 Between adjacent dynodes..... 250 V
 Between dynode No. 1 and cathode..... 400 B
 Average Anode Current:
 Averaged over any 30 second interval..... 20 µA
 Temperature Range:
 Operating:
 C31016G-90..... -30 to +90 °C
 C31016G..... -30 to +150 °C
 C31016H..... -30 to +175 °C
 Extended Storage (all types)..... -30 to +50 °C
 Lead Temperature:
 6.35 mm (0.25 in) from protective shell for 10 seconds maximum..... +250 °C

Performance Data

Data shown below are taken to characterize the photomultipliers and assure performance at the specified temperature ratings. Selection of PMT's by alternative testing procedures is recommended where parameters not listed below are deemed important to a specific application.

Under conditions with DC voltage (E) across a voltage-divider providing electrode voltage as shown in Table 1, and at a temperature of 22 °C, except as noted. Data refers to all types unless otherwise noted.

With E=1500 volts (except as noted)

	Min.	Typ.	Max.	Units
Anode Responsivity				
Radiant @370 nm ³ ...	-	3.1 x 10 ⁴	-	A/W
Luminous (2856 K) ⁴ ...	-	20	-	A/lm
Blue Response ⁵	1	3	-	A/inc lm
@90 °C.....	-	2.4	-	A/inc lm
@150 °C.....	-	1.8	-	A/inc lm
@175 °C.....	-	1.5	-	A/inc lm
Cathode Responsivity:				
Radiant @370 nm ⁶ ...	-	51	-	mA/W
Luminous (2856 K) ⁷ ...	-	33	-	μA/lm
Blue Response ⁸	3.2	5	-	μA/inc lm
@90 °C.....	-	4	-	μA/inc lm
@150 °C.....	-	3	-	μA/inc lm
@175 °C.....	-	2.5	-	μA/inc lm
Quantum Efficiency	-	17	-	%
@310 nm.....	-	17	-	%
Current Amplification				
(Gain)	-	6x10 ⁵	-	
Anode Dark Current ⁹ ...	-	0.1	10	nA
Rise Time ¹⁰	-	1.5	-	ns
Background (>75keV):¹¹				
@90 °C.....	-	-	50	cps
@150 °C.....	-	-	50	cps
@175 °C.....	-	12	50	cps

Notes

- Made by Corning Glass Works, Corning, New York.
- In accordance with the Absolute Maximum rating system as defined by the Electronic Industries Association Standards RS-239, formulated by the JEDEC Electron Tube Council.
- This value is calculated from the typical anode luminous responsivity value using a conversion factor of 1530 lumens per watt.
- Anode luminous responsivity is calculated as shown below:

$$\text{Anode luminous responsivity} = \frac{\text{Anode blue response (A/inc lm)}}{0.15} \text{ (A/lm)}$$

- The value of 0.15 is the average value of the ratio of the current measured under conditions specified in footnote (5) to the anode current measured under the same conditions but with the blue filter removed.
- Under the following conditions: Light incident on the cathode is transmitted through a blue filter (Corning C.S. No. 5-58, polished to ½ stock thickness) from a tungsten-filament lamp operated at a color temperature of 2856 K. The value of light flux incident on the filter is 1 x 10⁻⁶ lumen.

- This value is calculated from the typical cathode luminous responsivity value using a conversion factor of 1530 lumens per watt.
- Cathode luminous is calculated as shown below:

$$\text{Cathode luminous responsivity} = \frac{\text{Cathode blue response (}\mu\text{A/inc lm)}}{0.15} \text{ (}\mu\text{A/lm)}$$
- The value of 0.15 is the average value of the ratio of the current measured under conditions specified in footnote (8) to the anode current measured under the same conditions but with the blue filter removed.
- Under the following conditions: Light incident on the cathode is transmitted through a blue filter (Corning C.S. No. 5-58 polished to ½ stock thickness) from a tungsten-filament lamp operated at a color temperature of 2856K. The light flux incident on the filter is 1x10⁻³ lumen; 300 volts is applied between cathode and all other electrodes connected as anode.
- The supply voltage E is adjusted to 1500 volts. Dark current is measured with no light incident on the tube.
- Measured between 10 percent and 90 percent of maximum anode-pulse height. This anode-pulse rise time is primarily a function of transmit time variation and is measured under conditions with the incident light fully illuminating the photocathode.
- Background is defined as those dark counts that exceed the lower energy threshold level. For the C31016 family this lower energy threshold is considered to be 75 keV.

Environmental Design Test Description

The C31016 family is designed to withstand the environmental conditions listed below which are equivalent to those specified in MIL-STD-810B:

Shock – Two half-sine-wave shock pulses in each of three orthogonal axes (perpendicular and parallel to the plane of the electron multipliers shield and along the major axis of the tube.) Each impact shock has a peak acceleration of 75 ±7 g's and a time duration of 11 ±1 millisecond for a total of twelve shock pulses. The tube is non-operating.

Random Vibration – Random vibration in each of three orthogonal axes specified above. The tube is subjected to an acceleration power spectral density of 0.3 g²/Hz or an overall acceleration of 20.7 g (rms). This acceleration spectral density increases at a rate of 6 dB per octave between 50 and 100 Hz, is flat from 100 to 1000 Hz, and decreases at a rate of 6 dB per octave from 1000 to 2000 Hz. The sweep time per axis is 30 minutes and one sweep is performed on each of the axis for a total of 1.5 hours. The tube is non-operating.

Operating Considerations

Cathode Current

An average cathode current of 1 x 10⁻⁸ ampere at a tube temperature of 22 °C or 1 x 10⁻¹⁰ ampere at -85 °C should not be exceeded. Because of the resistivity of the photocathode, the voltage drop caused by higher average cathode currents may produce radial electric fields which can result in poor photoelectron collection on the first dynode. Photocathode resistivity increases with decreasing temperature.

Ambient Atmosphere

Operation or storage of this tube in environments where helium is present should be avoided. Helium may permeate the tube envelope and may lead to eventual tube destruction.

Shielding

Electrostatic shielding of the tube is ordinarily required. When a shield is used, it must be connected to the cathode terminal. The application of high voltage, with respect to cathode, to insulating or other materials supporting or shielding the tube at the photocathode end of the tube should not be permitted unless such materials are chosen to limit current to the tube envelope to 1×10^{-12} ampere or less.

In addition to increasing dark current and noise output because of voltage gradients developed across the bulb wall, such high voltage may produce minute leakage current to the cathode, through the tube envelope and insulating materials, which can permanently damage the tube.

Photocathode Sensitivity Change and Temperature

The Na_2KSb photocathode has a unique sensitivity characteristic versus increasing temperature as is shown in **Figure 4**. In spite of the loss in sensitivity with increasing temperature, pulse counts can be obtained in operation to at least 175°C for the C31016H. In addition, tubes with Na_2KSb photocathodes can be cycled many times into this high temperature range with only gradual degradation of the photocathode.

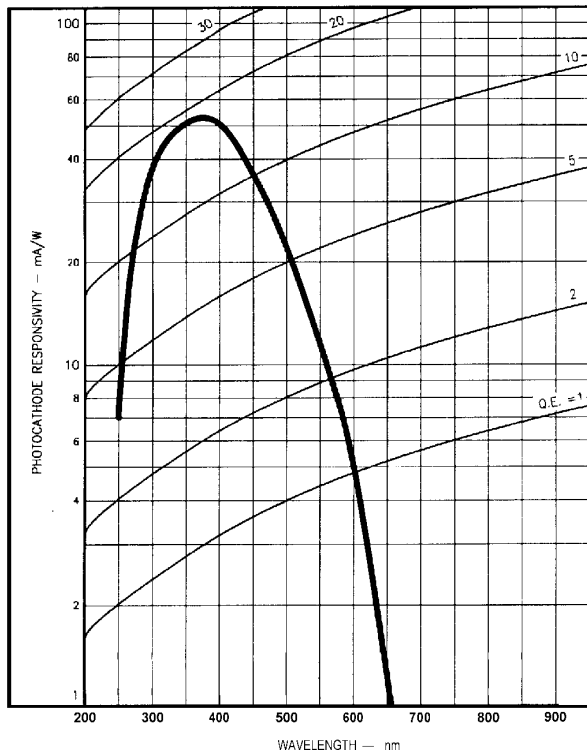

Figure 1 – Typical Photocathode Spectral Response Characteristics

Table 1

Typical Voltage Distribution	
Between	7.7% of Supply Voltage (E) Multiplied by:
Cathode and Dynode No. 1	3
Dynode No. 1 and Dynode No. 2	1
Dynode No. 2 and Dynode No. 3	1
Dynode No. 3 and Dynode No. 4	1
Dynode No. 4 and Dynode No. 5	1
Dynode No. 5 and Dynode No. 6	1
Dynode No. 6 and Dynode No. 7	1
Dynode No. 7 and Dynode No. 8	1
Dynode No. 8 and Dynode No. 9	1
Dynode No. 9 and Dynode No. 10	1
Dynode No. 10 and Anode	1
Anode and Cathode	13

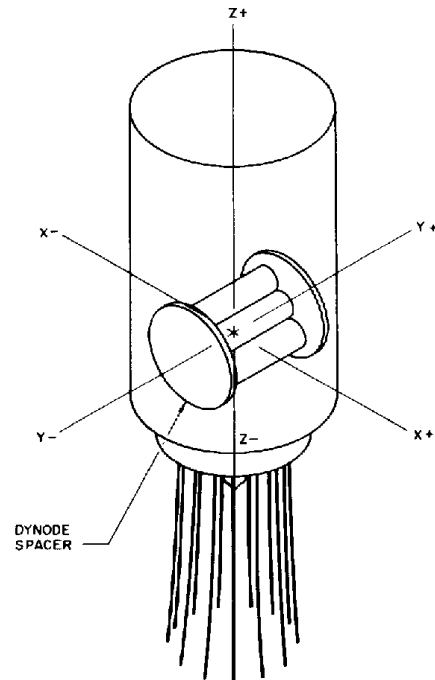

Figure 2 – Orthogonal Axes of Tube Used During Environmental Tests

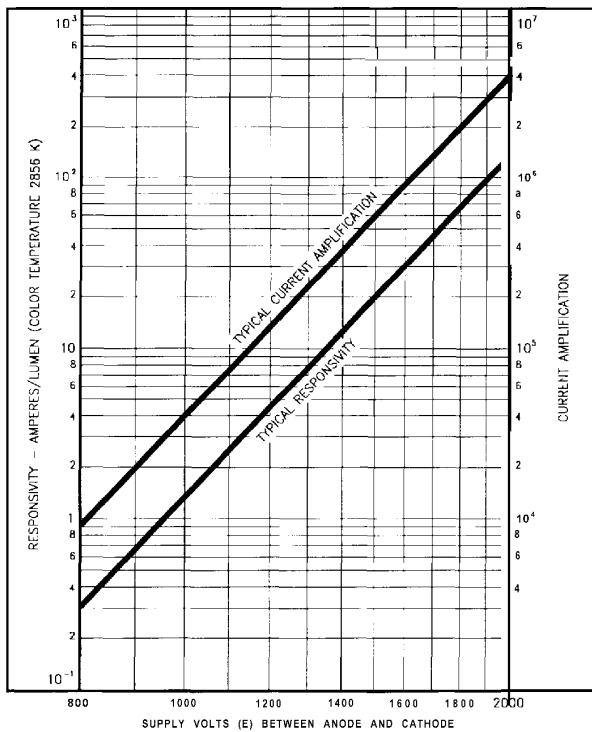
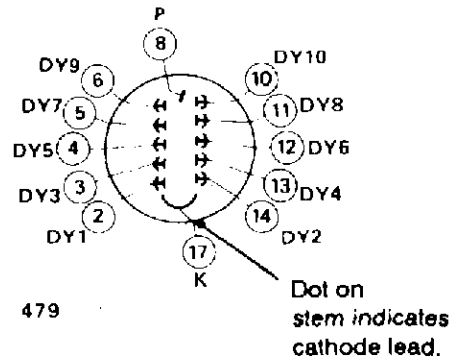
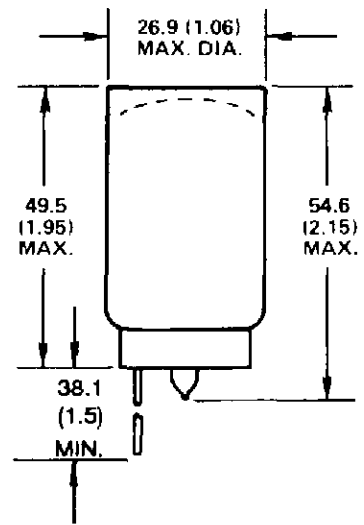

Figure 3 – Typical Current Amplification and Responsivity Characteristics



479

Dot on stem indicates cathode lead.

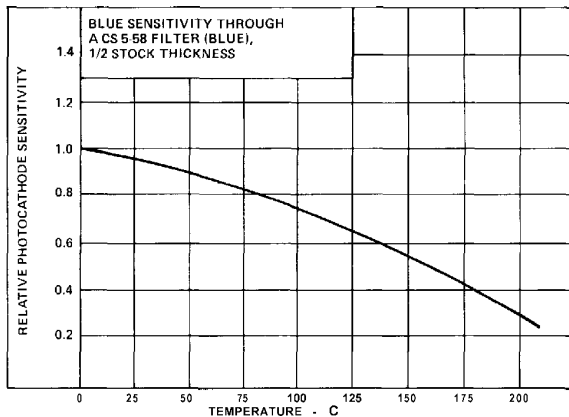
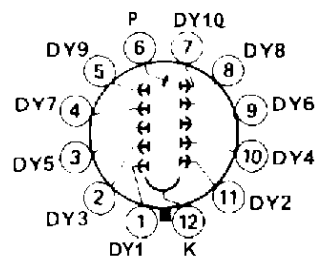

Figure 4 – Sodium Potassium Bialkali (Na₂KSb) Photocathode Sensitivity as a function of Temperature

- Note 1 - Deviation from flatness will not exceed 0.25 mm (0.010 inch) peak-to-valley. Faceplate material is Corning No. 7056, or equivalent. Its index of refraction at 391.4 nanometers is 1.50.
- Note 2 - Soldering or welding to the leads within this region is not recommended. For soldering temperature, see Maximum Ratings.
- Note 3 - A hole having a minimum diameter of 5.1 mm (0.20 inch) should be provided in circuit boards or similar mounting arrangements to allow clearance of the tubes exhaust tip.
- Note 4 - Typical socket, to facilitate testing prior to tube installation in a system, is BURLE AJ2259.
- Note 5 - Magnetic shielding of the tube is ordinarily required. Suggested source: Perfection Mica Company, Magnetic Shield Division, 740 North Thomas Drive, Bensonville, IL 60106. Phone 312-766-7800.



12AE

Figure 6 – Basing Diagram, Bottom View (For Temporary Base JEDEC No. B12-43)