

REV.	DATE	DESCRIPTION	BY	APP'D
1	10/88	BENT GAS TUBE FOR BETTER CONTACT	SPESE	
2	11/88	ADDED PART 8	URIBE	
3	6-89	ADDED PART 9	WAALER	
4	10-90	REVISED PARTS LIST FOR A VERSION	URIBE	

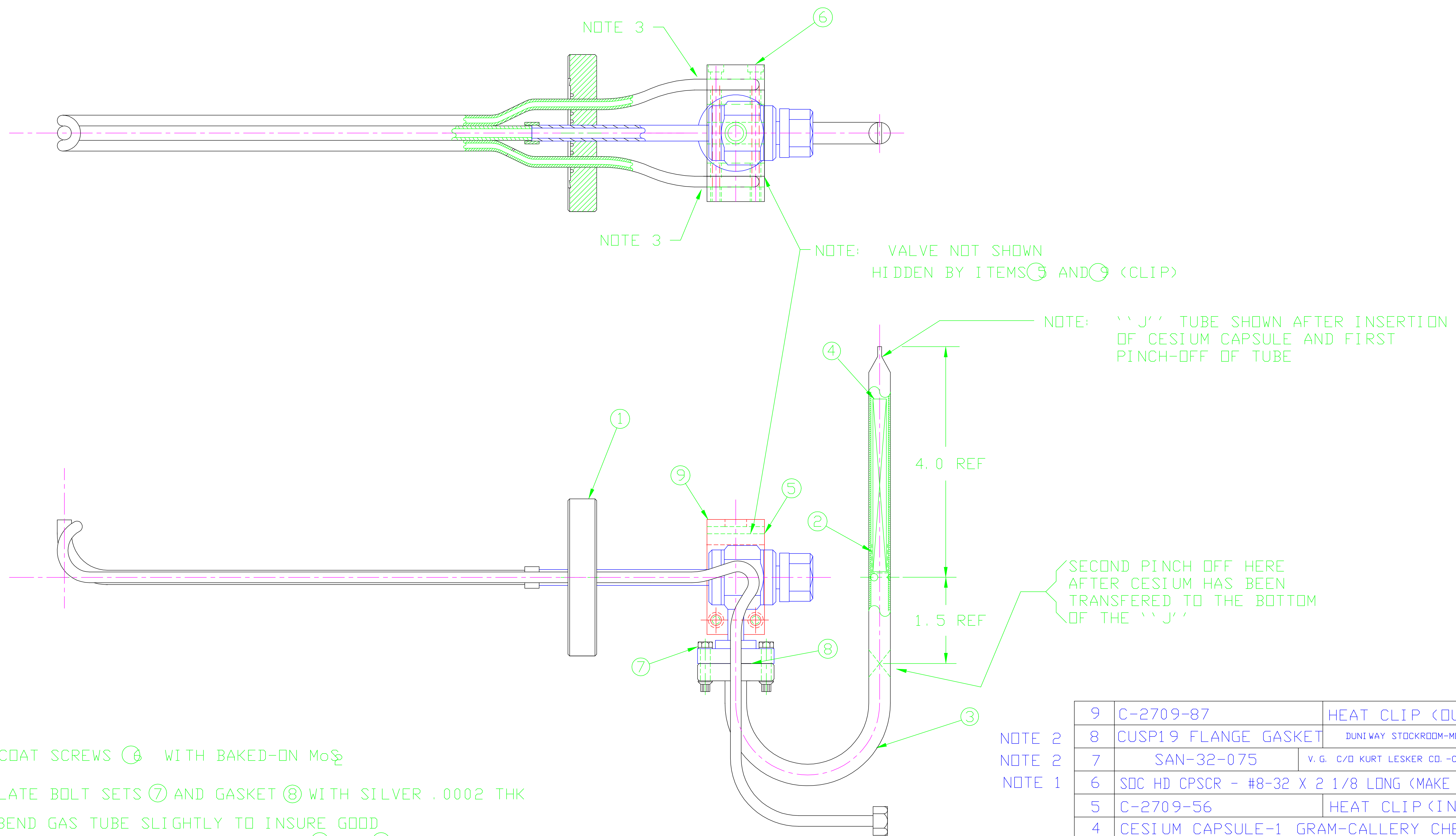

NOTES:

1. COAT SCREWS ④ WITH BAKED-ON MoS<sub>2</sub>
2. PLATE BOLT SETS ⑦ AND GASKET ⑧ WITH SILVER .0002 THK
3. BEND GAS TUBE SLIGHTLY TO INSURE GOOD THERMAL CONTACT WITH HEAT CLIPS ⑤ AND ⑨

NOTE 2  
NOTE 2  
NOTE 1

9	C-2709-87	HEAT CLIP (OUTER)	1
8	CUSP19 FLANGE GASKET	DUNIWAY STOCKROOM-MOUNTAIN VIEW, CALIF. 94043	1
7	SAN-32-075	V. G. C/D KURT LESKER CO.-CLAIRTON, PA 15025 BOLT SET (6)	1
6	SDC HD CPSCR - #8-32 X 2 1/8 LONG (MAKE FROM ALLTHREAD ROD)		2
5	C-2709-56	HEAT CLIP (INNER)	1
4	CESIUM CAPSULE-1 GRAM-CALLERY CHEMICAL CO.		1
3	C-2709-47	CESIUM TUBE	1
2	C-2709-52	CAPSULE FILTER	1
1	C-2709-44A	CESIATOR WELDMENT	1
ITEM PART NO.		DESCRIPTION	QTY
DRAWN BY SPESE		NUCLEAR PHYSICS LABORATORY UNIVERSITY OF ILLINOIS AT URBANA-CHAMPAIGN	
CHECKED BY		CESIATOR ASSEMBLY	
APPROVED BY		UNLESS OTHERWISE SPECIFIED	
		PART NO.	
		NO. REQ'D.	
		SCALE	
		FILE	
		1=1	
		15	
		DATE	
		10-15-90	
		DWG. NO.	
		90-2709-14	
		LISTED	