

REV.	DATE	DESCRIPTION	BY	APP'D
1	10/88	EDITED NOTES 2 AND 3	URIBE	

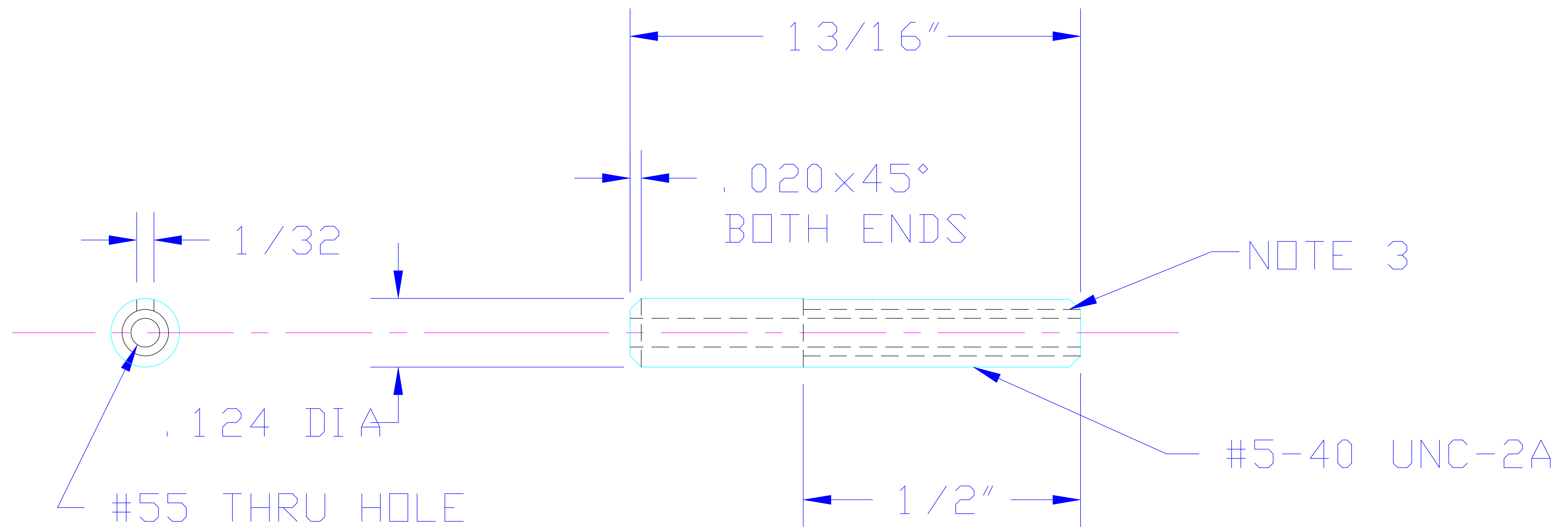

### NOTES

1. MAT'L: 1/8 DIA 304 SST
  2. SILVER PLATE .0002 THK
  3. VENT SLOT TO A DEPTH SLIGHTLY DEEPER THAN THE DEPTH OF THE MINOR DIA. OF THREAD FOR LENGTH OF THREAD
  4. ALL MACHINING TO BE DONE WITH SULFUR-FREE CUTTING OIL.
- SLAC: PF795-641-10-R0 MODIFIED

TOLERANCES  
 FRACT  $\pm 1/64$   
 $\frac{32}{\checkmark}$

DRAWN BY URIBE	NUCLEAR PHYSICS LABORATORY UNIVERSITY OF ILLINOIS AT URBANA-CHAMPAIGN	ANODE LOCATING PIN		
CHECKED BY	UNLESS OTHERWISE SPECIFIED	PART NO.	SCALE 5=1	FILE 12
APPROVED BY	DIMENSIONS IN INCHES 2 PLACE DEC. $\pm .01$ BREAK SHARP CORNERS 3 PLACES DEC. $\pm .003$ FRACTIONAL $\pm 1/32'$ ANGULAR $\pm 0'30'$	NO. REQ'D.	DATE 7-10-88	DWG. NO. C-2709-43
		CHASSIS NO. OR MATERIAL LISTED		