

REV.	DATE	DESCRIPTION	BY	APP'D
1	12-88	ADDED HOLE SIZE & NOTE 3	SPESE	
2	6-89	CHANGED HOLE SIZE TO 1/8"	WAALER	

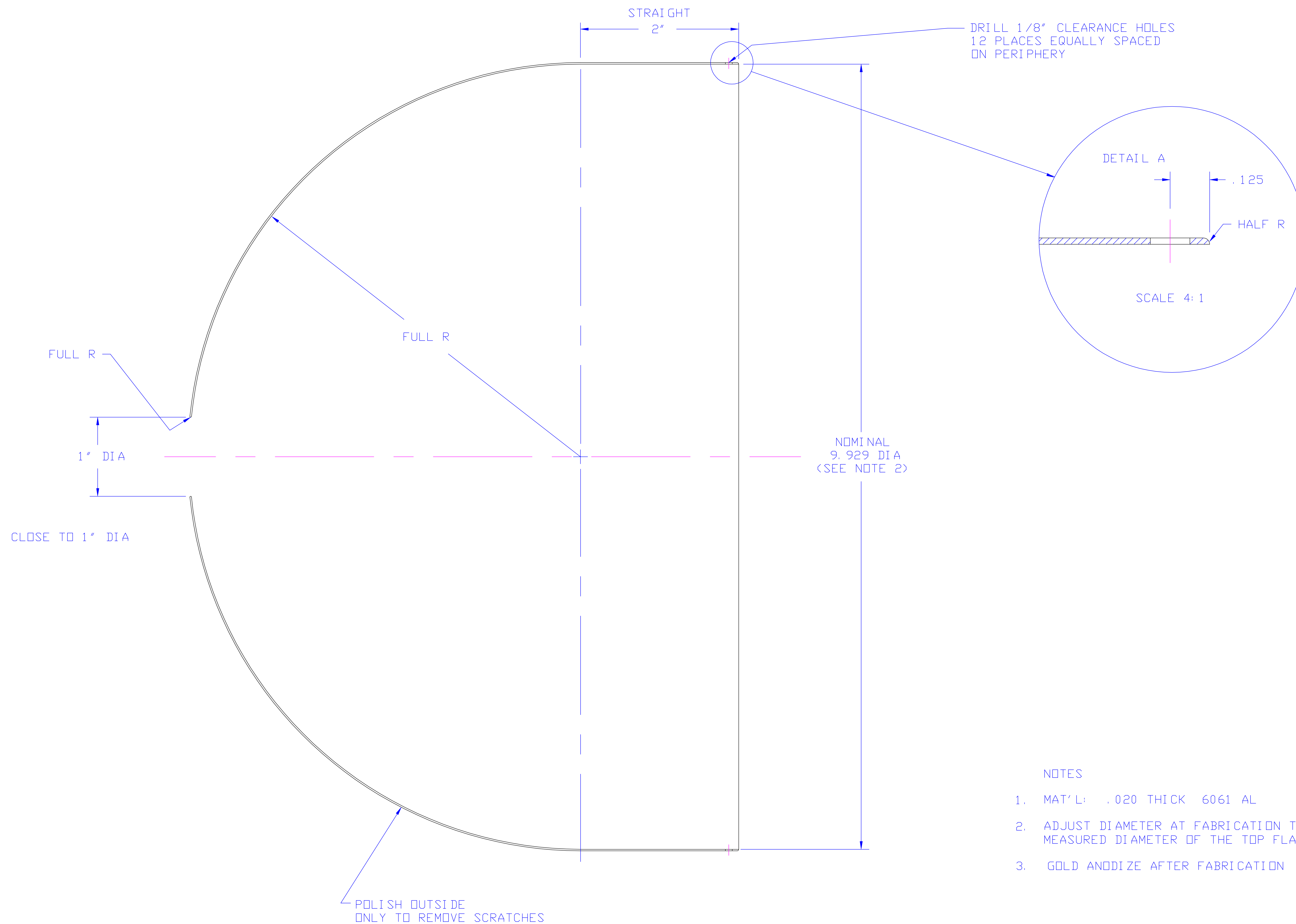

NOTES

- MAT'L: .020 THICK 6061 AL
- ADJUST DIAMETER AT FABRICATION TO MATCH MEASURED DIAMETER OF THE TOP FLANGE (2706-31)
- GOLD ANODIZE AFTER FABRICATION

DRAWN BY URIBE	NUCLEAR PHYSICS LABORATORY UNIVERSITY OF ILLINOIS AT URBANA-CHAMPAIGN	DOME		
CHECKED BY	UNLESS OTHERWISE SPECIFIED	PART NO.	SCALE 1=1	FILE 12
APPROVED BY	DIMENSIONS IN INCHES 2 PLACE DEC. ± .01 BREAK SHARP CORNERS 3 PLACES DEC. ± .003 FRACTIONAL ± 1/32" ANGULAR ± 0° 30'	NO. REQ'D.	DATE 7-10-88	DWG. NO. C-2709-49
		CHASSIS NO. OR MATERIAL LISTED		