

DRAWN	hansknec	11/21/2007	material = polycarbonate	
CHECKED			TITLE	
QA			anodizer end walls (1 of 2)	
MFG			SIZE	DWG NO
APPROVED			B	wall 0
			SCALE	REV
				SHEET 1 OF 1

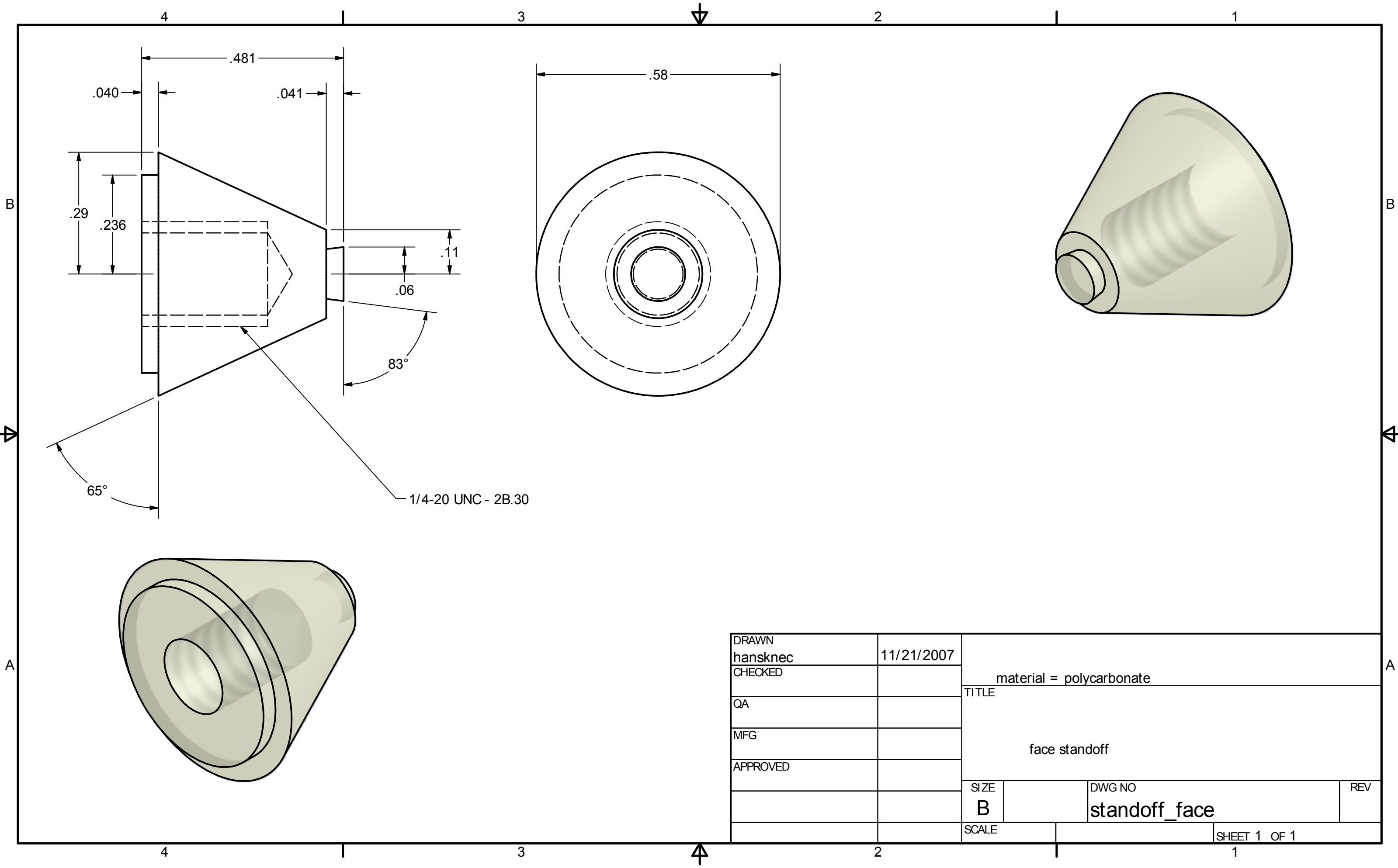

DRAWN	hansknec	11/21/2007	material = polycarbonate	
CHECKED			TITLE	
QA			face standoff	
MFG			SIZE	DWG NO
APPROVED			B	standoff_face
			SCALE	REV
				SHEET 1 OF 1

4 3 2 1

B

B

1/4-20 UNC - 2B 6 places
tapped to .5" from both sides (or thru)

G 1/4 - NPT thru both sides

6-32 UNC - 2B.38

O-ring
grove both sides

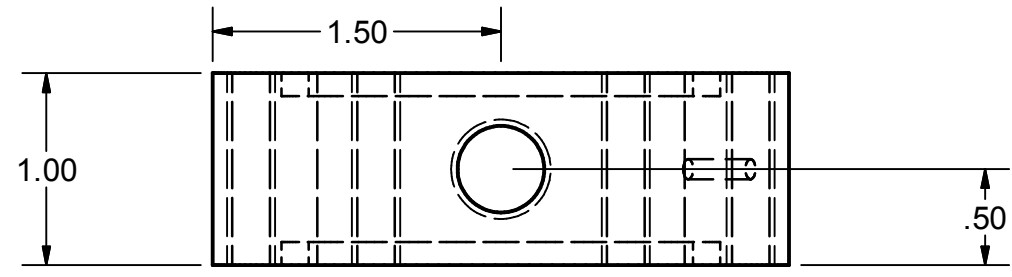
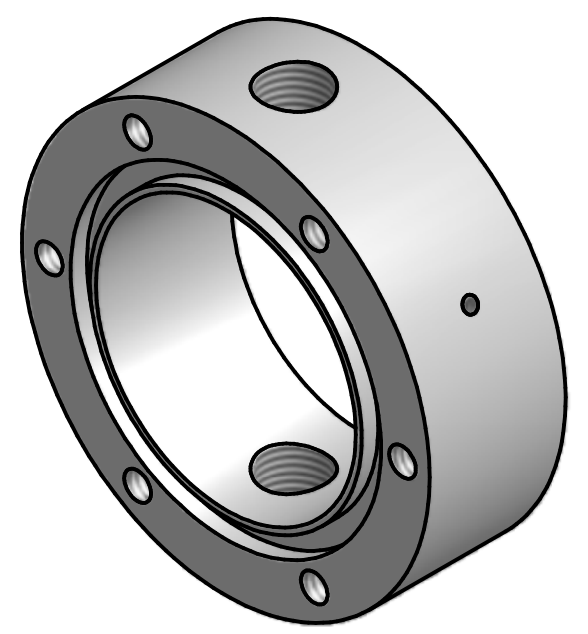
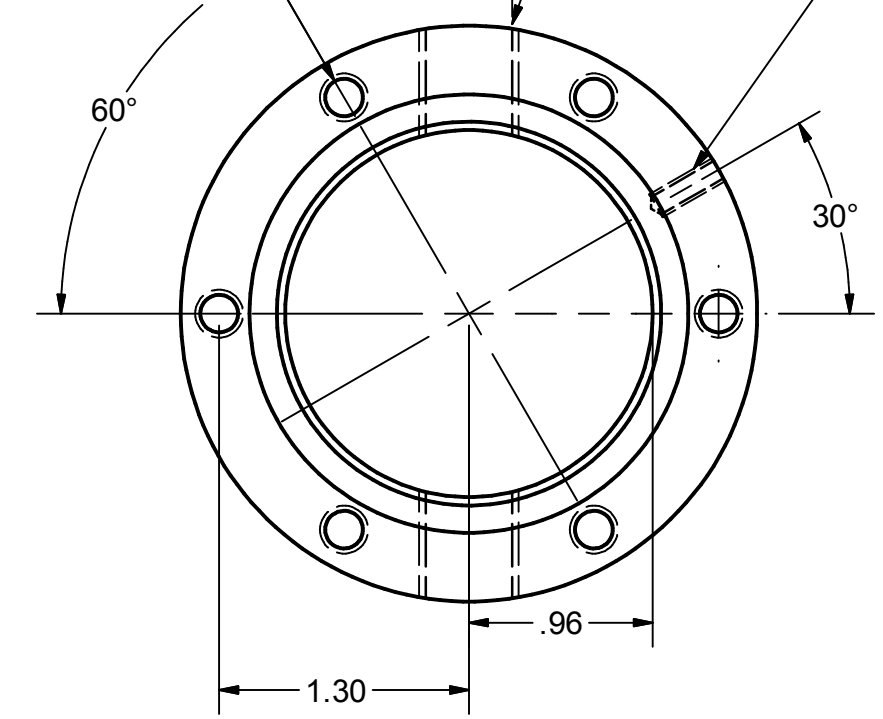
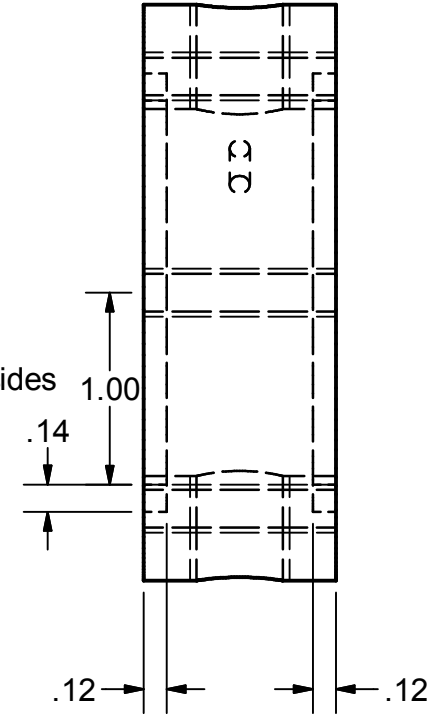

A

A

A

A

DRAWN	hanskne	11/21/2007	Material = Aluminum	
CHECKED			TITLE	
QA			Anodizer anode ring	
MFG			SIZE	DWG NO
APPROVED			B	anode ring
			SCALE	REV
				1

4 3 2 1

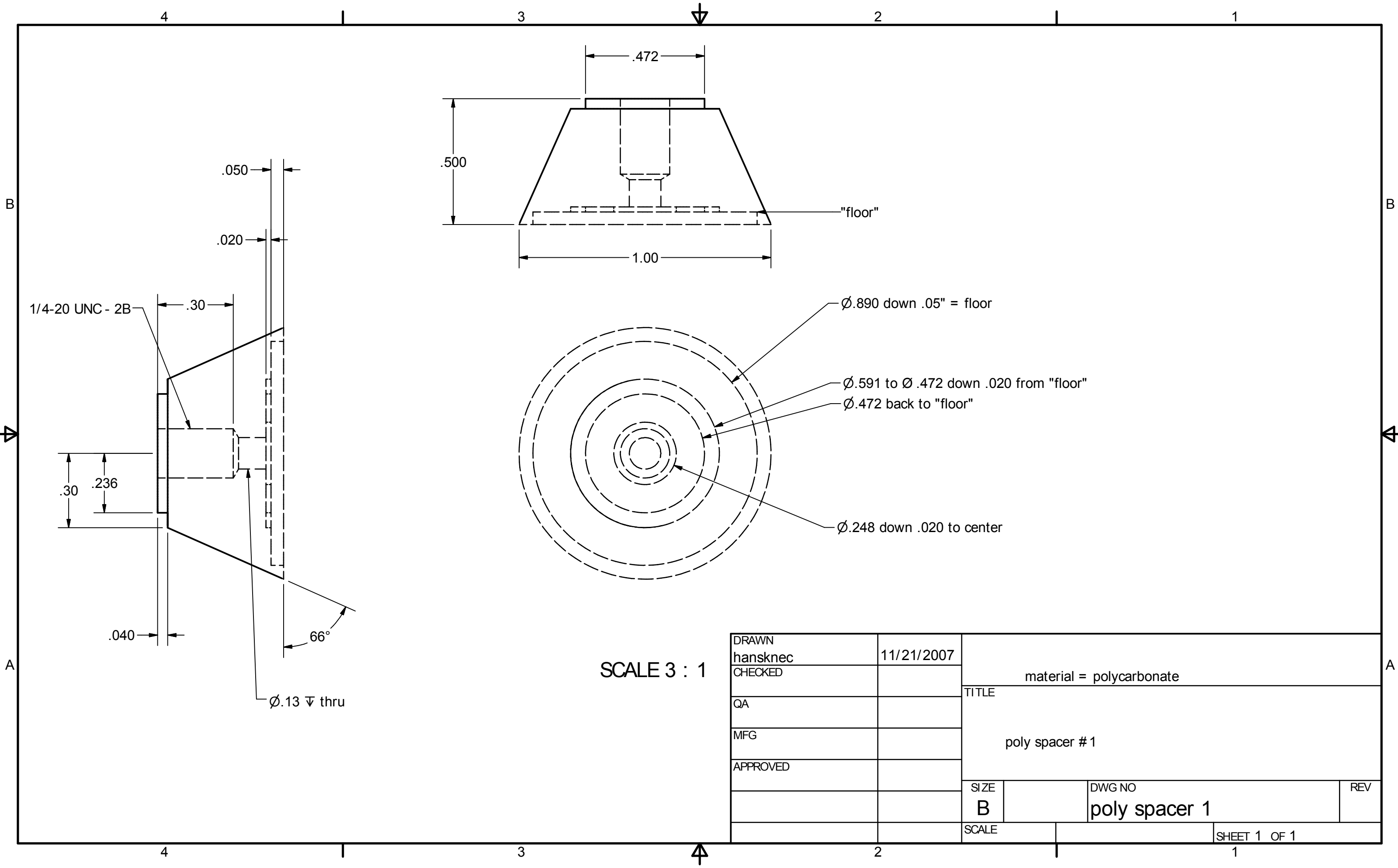

SCALE 3 : 1

DRAWN	hansknec	11/21/2007	material = polycarbonate	
CHECKED			TITLE	
QA			poly spacer # 1	
MFG				
APPROVED				
		SIZE	DWG NO	REV
		B	poly spacer 1	
		SCALE	SHEET 1 OF 1	