

Temple University  
Polarized  $^3\text{He}$  Lab  
Technical Note  
March 10, 2001

**Improving SNR for water calibration  
of the polarized  $^3\text{He}$  NMR system.**

K. Slifer  
Temple University, Philadelphia, PA 19122  
E-mail  
kslifer@temple.edu

# Contents

|          |  |          |
|----------|--|----------|
| <b>1</b> | <b>Introduction</b>                      | <b>3</b> |
| <b>2</b> | <b>Cabling</b>                           | <b>3</b> |
| <b>3</b> | <b>Device Configuration</b>              | <b>3</b> |
| <b>4</b> | <b>Minimizing the Pickup Coil Output</b> | <b>5</b> |
| <b>5</b> | <b>Improving the Signal to Noise</b>     | <b>6</b> |
| <b>6</b> | <b>TroubleShooting</b>                   | <b>6</b> |
| <b>7</b> | <b>Electronic Noise Sources</b>          | <b>8</b> |
| <b>8</b> | <b>Appendix: Capturing Scope Traces</b>  | <b>9</b> |

# 1 Introduction

The NMR system of the polarized  $^3\text{He}$  group is used to determine the polarization of  $^3\text{He}$  target cells. This note is intended as a “nuts and bolts” account of the method used to calibrate the system, focusing on the details that are typically left out of most theoretical descriptions. Nevertheless, in order to provide some context, we include an (extremely) brief description of AFP NMR. For a more detailed account of the theory, see [1] or [2]

The  $^3\text{He}$  target cell is placed in an homogenous magnetic field produced by a Helmholtz coil pair. At the same time an RF magnetic field is produced by a second Helmholtz pair, orthogonal to the original set. The polarization is measured by holding the RF frequency fixed and sweeping the main magnetic field through the RF resonance. At resonance, the spins flip and this is detected by a pair of pickup coils placed around the cell. The precessing  $^3\text{He}$  nuclei induce an AC voltage in the pickup coils which is detected with a Lock-In amplifier referenced to the RF frequency. This signal is proportional to the  $^3\text{He}$  polarization. An absolute polarization can be determined by calibrating the NMR apparatus with a geometrically identical water sample. The polarization of the water sample is known in advance, as it follows a Boltzman distribution.

This straightforward calibration method is complicated by the small Signal to Noise Ratio (SNR) observed during water NMR. In order to make this procedure somewhat easier to reproduce we will describe the method in detail as well as the device configuration that was used for a successful scan on February 18-19, 2001.

## 2 Cabling

Fig. 1 shows the cabling of the devices in the NMR system. Where applicable, the GPIB address of the device is also given. Fig. 2 shows the Kepko Power Supply connection in detail. The figures are mostly self-explanatory. We add the following notes:

1. The Front panel connection from the SRS DS345 function generator to the Kepko Power supply must be from red cable to red post, black wire to black post.
2. The SRS DS345 FG rear panel **OUTPUTS TRIGGER** should be connected to the Lock-In Amplifier rear panel **TRIG IN**. This connection provides the trigger for the Lock-In amplifier to start data logging at the start of a sweep.
3. The **loop OSCOPE** is connected to a small toroid that is intersected by the RF drive line. This measures the current through the RF coils. The calibration is such that a 1 VRMS output indicates that 1 Amp RMS is passing through the toroid. A schematic of the toroid is shown in Fig. 10

## 3 Device Configuration

1. HP 3325B Function Generator

- 0.5 Vrms amplitude
- 91 kHz frequency

## 2. Attenuator

- Three  $50\ \Omega$  attenuators are placed in series with the ENI RF Amplifier to ensure that the Maximum input voltage of 1 Vrms is not exceeded.

## 3. Capacitor Box

- This device serves two purposes, both unutilized at present.
  - (a) It can be used to change the resonant frequency of the RF drive circuit. This was necessary at JLAB to overcome the power loss along the long transmission lines.
  - (b) The secondary output **OUTPUT/Q-CURVE** is intended for use with a small excitation loop to be placed near the pickup coils for Q-curve monitoring.

## 4. SRS SR844 Lock-In Amplifier

- Reference phase  $\phi$ : -78.09 when RF amplitude is 0.5Vrms
- Reference phase  $\phi$ : -162.00 when RF amplitude is 1.0Vrms
- $\tau=10$  ms
- 24 dB/octave rolloff
- $50\ \Omega$  "Signal In" impedance
- Low noise (close reserve)
- X channel offset
- reference input impedance  $10k\Omega$  ,40pF
- X channel  $\sim 168$ mV before offset. Y channel  $\sim 0.0$ mV.  
NMR Signal visible after 1 sweep\*

## 5. SRS SR830 Lock-In

- The SR830 has a lower frequency range than the SR844 but is virtually identical otherwise. As a backup it can replace the SR844 with no change in software.

## 6. Kepko DC Power Supply

- Driven from the SRS DS345 FG through the Kepko front panel inputs
- Ramp: 5.167 to 7.251 Amps (ammeter reading)

---

\*Five extra water cells in coils (see section 5). X drifted to about 250 mV after 1 hour. Signal was then visible after 2-3 sweeps. The signal from the pickup coils had been minimized just prior to the 168 mV reading so the drift from 168mV to 250 mV was probably due to the coils settling into their new configuration.

- Ramp: 5.22 to 7.32 Amps (Kepko front panel)
- Ramp: 15.7 to 22.0 Volts (Kepko front panel)

#### 7. Ammeter

- DC Current mode to monitor the current to the Large Helmholtz coils.

#### 8. Preamplifier

- 10kHz to 100kHz Bandpass filter
- AC couple
- A-B configuration
- Low noise
- **Amplification** : X200
- 50  $\Omega$  output
- powered by AC line

#### 9. Pickup coils

- The coils were wrapped on October 15, 1997 with 28 AWG wire. There are 21 layers with 8 turns per layer. They have identical impedance, 4.83mH, with a Q of 67. The dimensions are detailed in Fig. 9
- The water cell was designed and filled by Alexander Lukanin with deionized water from PTI Process Chemicals.

## 4 Minimizing the Pickup Coil Output

The output of the pickup coils is amplified by the preamplifier before being routed to the Lock-In amplifier. In order to avoid an overload of the Lock-In, it is desirable to reduce the pickup coil output before amplification. Note, we are trying to minimize the "bleedthrough" of the always present RF magnetic field into the pickup coils. This component of the detected signal is useless and only creates an offset from zero in the Lock-In.

Minimization is accomplished by adjusting the orientation of the pickup coils with respect to the RF field. A very small adjustment in inclination will be quite noticeable. The output of the pickup coils should be fed to the inputs of the oscilloscope where the amplitude of each can be compared. Then the platform inclination should be adjusted to minimize the difference of the two coils. Fig. 3 shows the left and right pickup coil signal, and the difference, which has been minimized.

Once the signal has been minimized, the two leads are fed to the preamplifier which takes the difference and amplifies. This output should then be examined again on the scope. The amplification will enable an even better minimization. Fig. 4 and Fig. 5 show further details of this process.

It is best not to completely reduce the value of A-B using this method. It seems that either the Preamplifier or Lock-In amplifier enters into an unstable mode of operation when there is *no* residual signal from the pickup coils. The noise level increases dramatically and the NMR signal is lost to the background. To avoid this, ensure that the signal after amplification is still recognizable as a clean sinusoidal wave, without too much fluctuation. See Fig. 4.

## 5 Improving the Signal to Noise

The most troublesome factor in performing a water calibration is the poor Signal to Noise Ratio (SNR). This is usually overcome by averaging many individual sweeps together. The NMR signals add coherently while the noise, being random, averages to zero. This can be a quite tedious procedure, as dozens of sweeps are usually needed before the NMR peak grows from the background. When a system is initially being calibrated, or if the system has been in disuse for some time, it is likely that some component is misconfigured or some bug has crept into the software. Countless hours can be lost attempting to obtain the signal by brute force averaging, only to later discover there is a simple cabling error. To avoid this, while simultaneously overcoming the poor SNR, it is advantageous to "cheat" when initially searching for the signal. There are two easy ways to improve the SNR.

1. Boost the signal. We can increase the number of proton spins within the coils simply by adding some extra water. Five small extra cells were placed on top of the water cell to boost the signal initially. The small water cells contain deionized water from Dr. Jeff Martoff's clean room.
2. Decrease the background. This is most easily done by decreasing the RF amplitude. This reduces the amount of pickup coil bleedthrough and enables very large amplification by the Preamp.

Fig. 7 shows the cheaters version of a Water NMR signal. Of course once the signal has been observed, the boost water must be removed and the RF amplitude must be increased. The advantage is that now it will be apparent that the NMR system is operational and the time consuming process of signal averaging can be started with confidence that the NMR signal will grow from the background. Fig. 8 shows the result of a true water calibration

## 6 TroubleShooting

The water NMR signal can be quite elusive even using the unorthodox methods of the previous section. What follows is some suggestions when all else fails.

- The lockin phase angle can be used to move an NMR signal that is split between X and Y exclusively into a single channel. Incrementing the phase by 15-20 degrees over several runs (while leaving all other parameters untouched) will often result in the signal becoming visible.

- The Lock-In should be located as far as possible from the other electronic devices, especially the Kepko power supply and the ENI power supply. These are both producers of copious amounts of electronic noise.
- Efforts should be made to isolate the pickup coils from any ambient air currents or vibrations as these lead to microphonic noise in the pickup coils.
- The Scope can be used quite effectively to track down any electronic source of noise by using the Fourier Fast Transform (FFT) feature. See section 7
- The pickup coil resonance frequency can be moved closer to the reference frequency of 91 kHz by introducing a capacitor into the pickup circuit. This is a little tricky though as the coil gain around resonance can change very easily due to temperature fluctuations or slight capacitative changes in the circuit.
- Water Calibrations have historically been more successful at night. Possible explanations for this strange fact:
  - Reduced activity in the building leading to less microphonics
  - Reduced computer/electronic equipment usage.

## 7 Electronic Noise Sources

The following represents a list of electronic noise sources and their signature frequencies. Those that are closest to the reference frequency of 91 kHz will be the most disruptive. The list was compiled in 1998 while working in the EEL building at Jefferson Lab. The devices at Temple are practically identical, so the values should still be relevant. Almost all the frequency values were determined using the Tektronix TDS 340A Digital Oscilloscope, which ironically produces noise at 94.7 kHz. This was determined using the Lock-In itself.

| Frequency (kHz)       | Source   |
|-----------------------|--|
| 5.5                   | Magnetic Probe   |
| 27 and 68             | Preamplifier running from line instead of battery.   |
| 68.65                 | Macintosh  |
| 74.5                  | NCD X-Terminal monitor   |
| 74.5                  | ENI RF Power Amplifier(along transmission line)  |
| 78                    | Overhead Fluorescent lights. 1st/2nd Floor   |
| <b>94.7</b>           | <b>Digital Oscilloscope.</b> (Measured using the Lock-In)  |
| 397.1                 | Kepko Power supply. Aliases at 97.5 kHz when the sample rate is low. This can be remedied with capacitors across the sense terminals but there is still a residual effect.   |
| 0.877                 | Kepko pulses in current mode. Also contains much higher frequency component(75 and 88kHz). The pulse frequency changes linearly from 877 to 250 Hz when the current is varied from 0 to 7 amps. This can be remedied (completely?) with 1 microF capacitors across the output. |
| High frequency spikes | Enet-GPIB terminal   |



## 8 Appendix: Capturing Scope Traces

To create screen captures on the Tektronix TDS 340A:

1. Insert IBM PC formatted disk
2. select UTILITY
3. select SYSTEM I/O
4. select HCP FORMAT
5. select EPS IMAGE
6. hit RUN/STOP
7. hit HARDCOPY

The SAVE/RECALL can save waveforms in microsoft excel format as well

### References

- [1] *Laser Polarized  $^3\text{He}$  Target Used for a Precision Measurement of the Neutron Spin Structure*, Mikhail V. Romalis, June 1997 Ph.D. Thesis
- [2] [www.jlab.org/e94010/tech\\_notes.html](http://www.jlab.org/e94010/tech_notes.html). Hypertext Document. See the numerous notes pertaining to NMR.
- [3] 314159265



Figure 1: Schematic of NMR system at Temple.

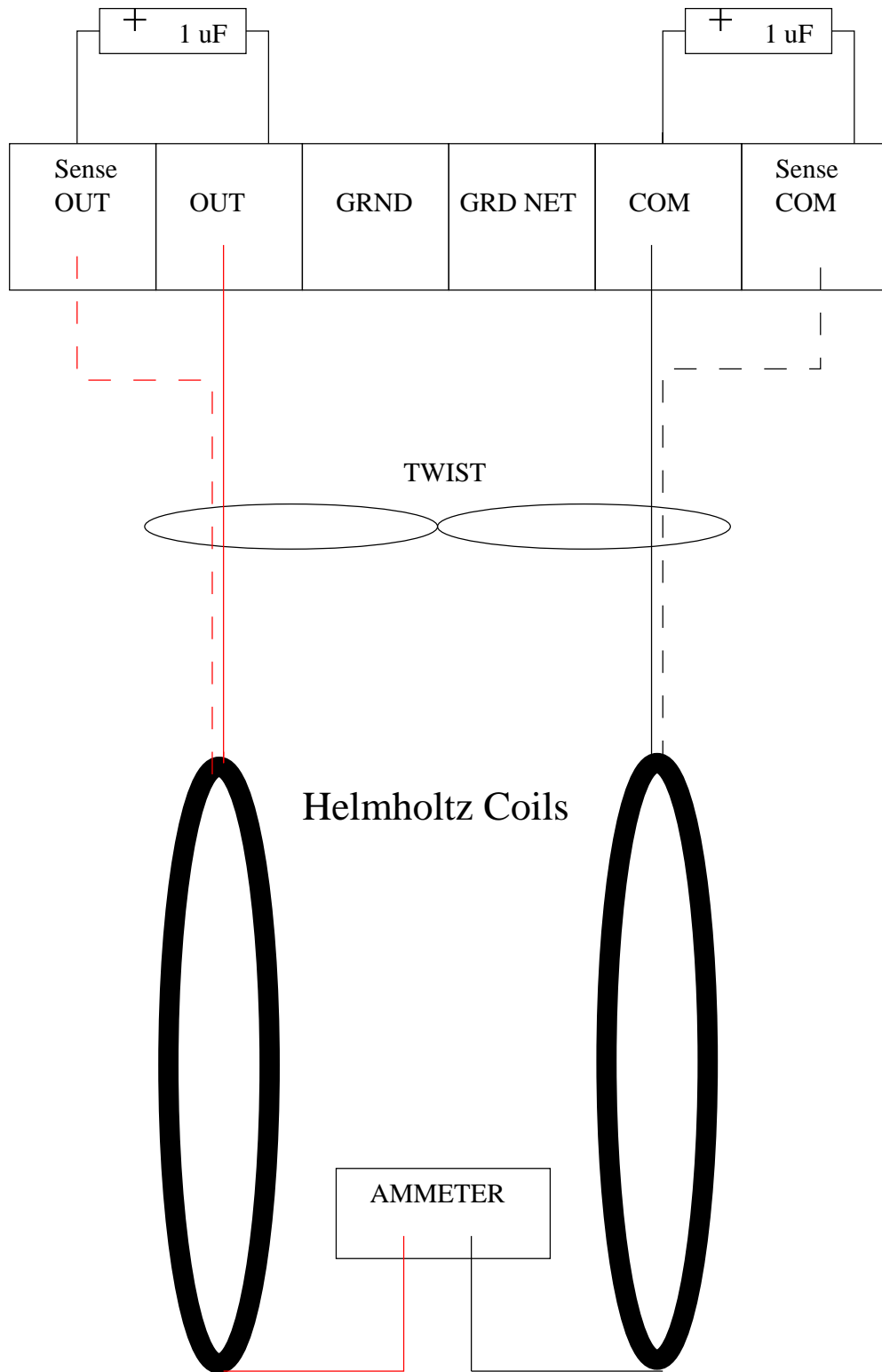

Figure 2: Kepko Power Supply Backpanel Wiring.

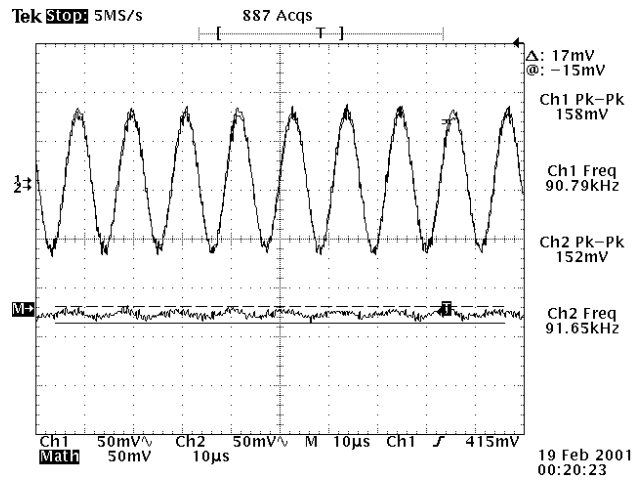

Figure 3: Unamplified output of pickup coils and their difference.

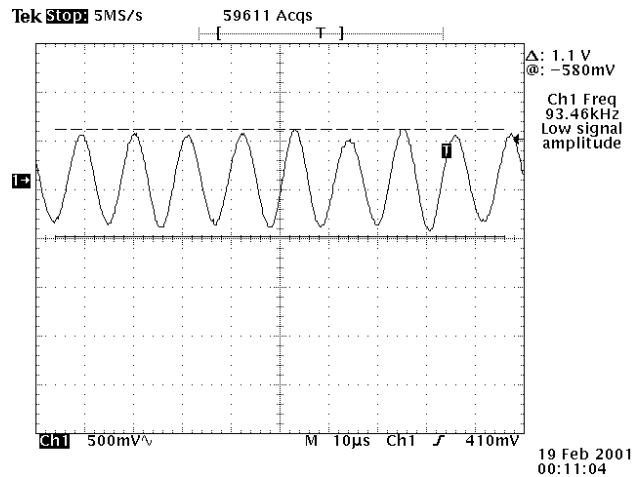

Figure 4: Output of the preamplifier A-B X200. There was a small but noticeable fluctuation to the signal as can be seen by the asymmetric amplitude. This signal represents a compromise of minimizing the signal amplitude while simultaneously minimizing the fluctuation.

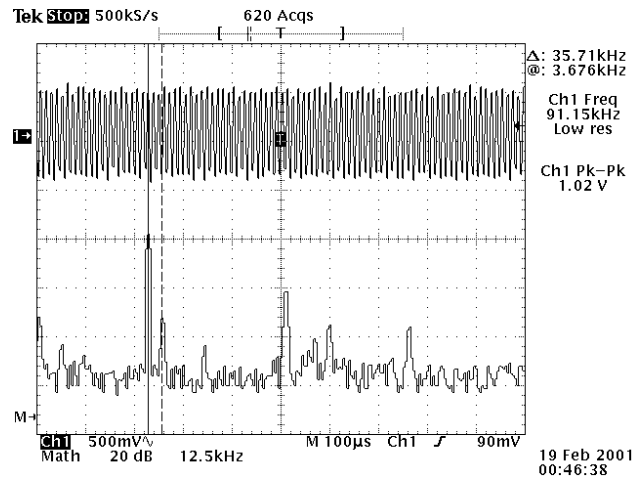

Figure 5: Output of preamp A-B amplified by 200, and the Fourier Fast Transform. The 91 KHz signal is in the left quadrant (solid vertical cursor). Note the large component at 94.7kHz (dashed vertical cursor) just to the right of 91 kHz. This is the noise signature of the digital Oscilloscope. The spike near center screen is an undetermined noise source.

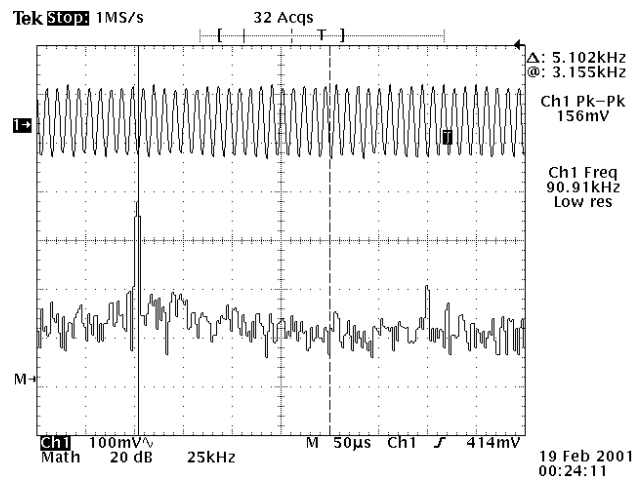

Figure 6: Left pickup coil direct into scope and its Fourier Fast Transform. Note that the 94.7kHz component is absent, indicating that it is caused by direct pickup by the preamplifier of the Scope noise.

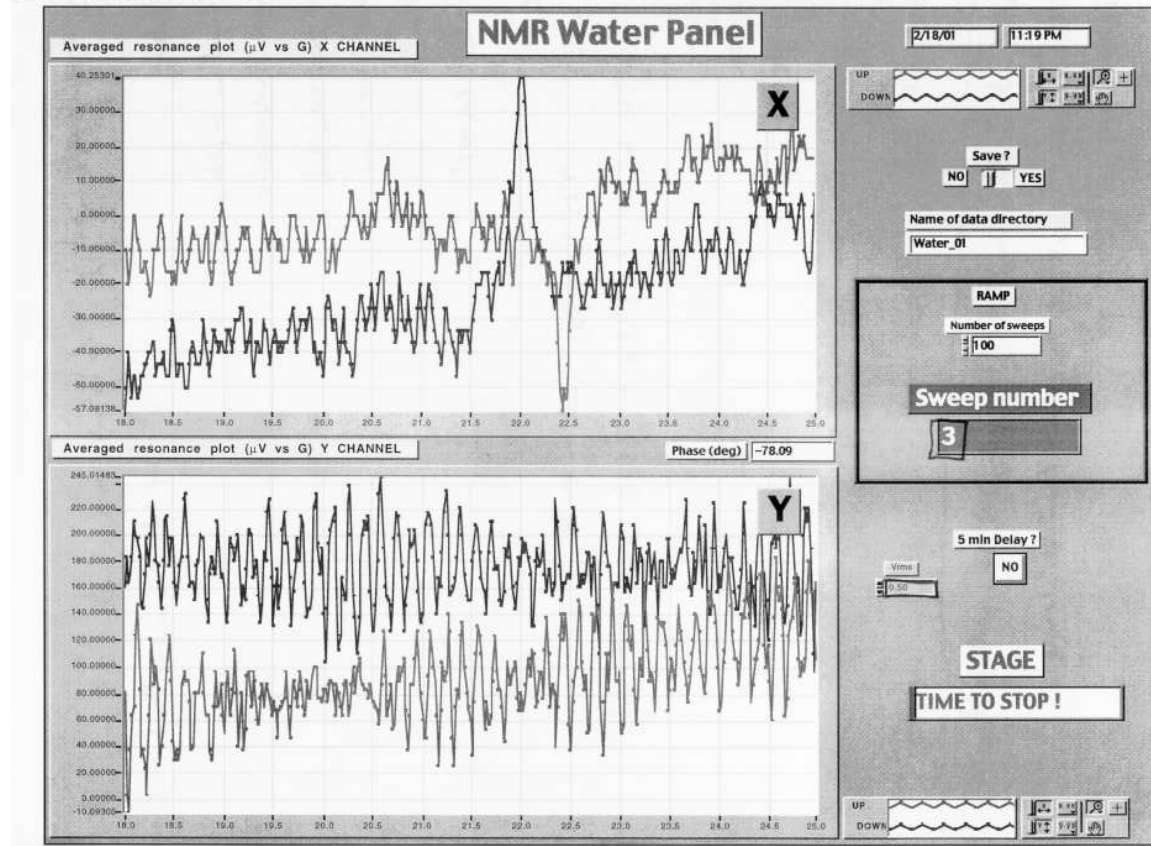

Figure 7: Water NMR signal. FG voltage is 0.5 Vrms and boost water present. All other device parameters listed in section 3. Screen capture was made after 3 sweeps.

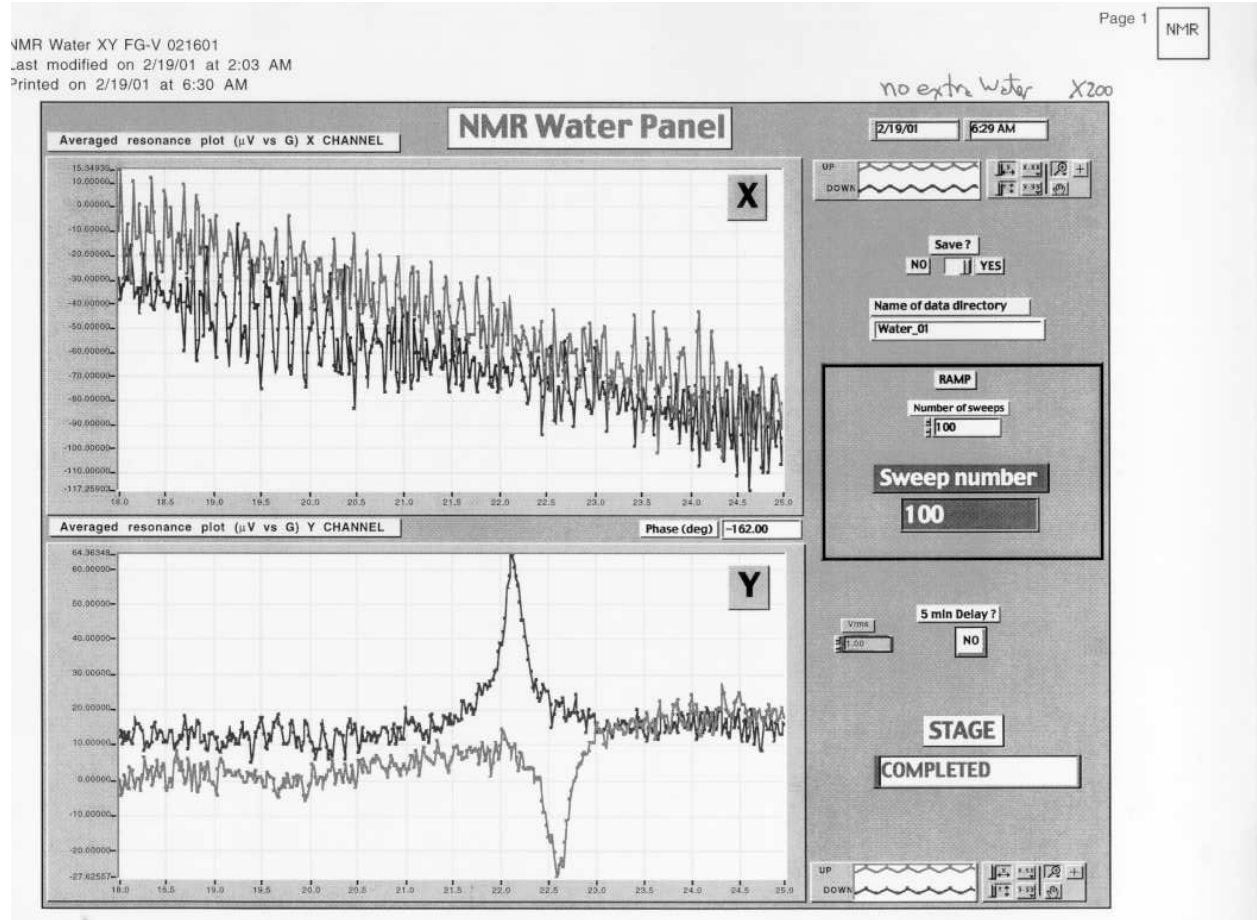

Figure 8: NMR signal used for calibration. Note the RF Amplitude has been increased and the extra booster water has been removed. All other device parameters remain unchanged. Screen capture was made after 100 sweeps.

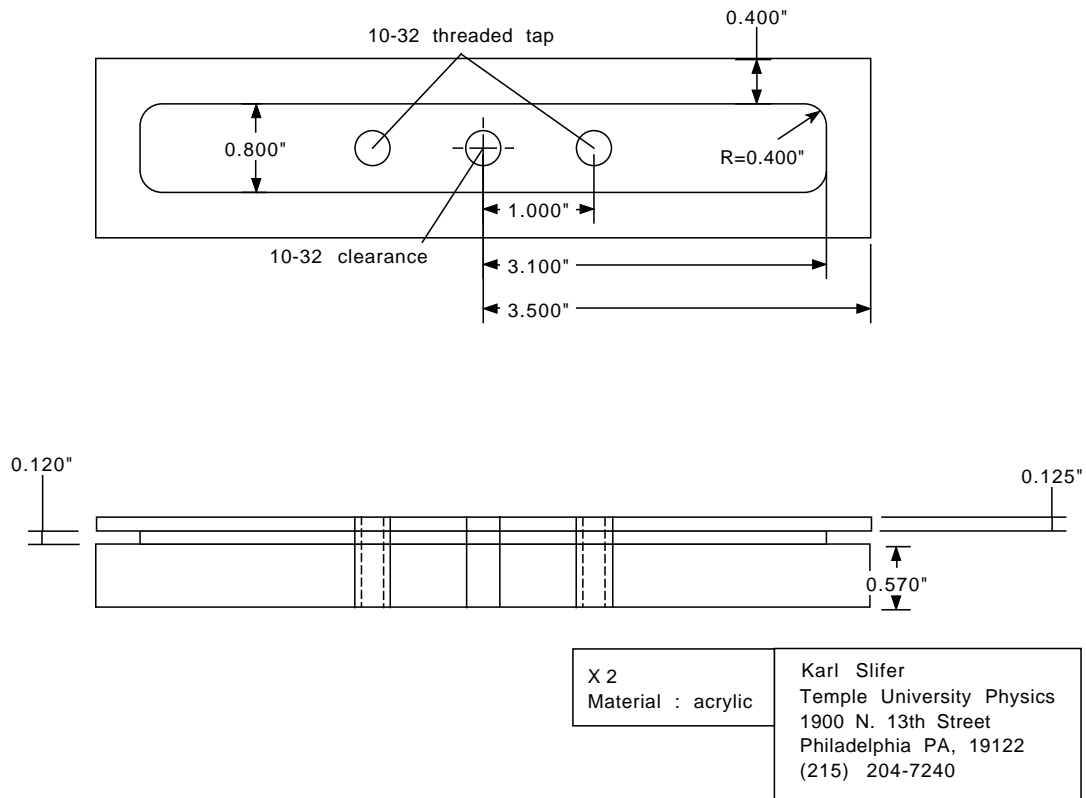

Figure 9: Design Schematic of Pickup Coils.



**PEARSON ELECTRONICS, INC.**  
1860 Embarcadero Road, Palo Alto, California 94303 U.S.A.  
Telephone 650-494-6444 \* FAX 650-494-6716  
e-mail: sales@pearsonelectronics.com

**Figure F** \* Models 2877, 2878 and 2879.

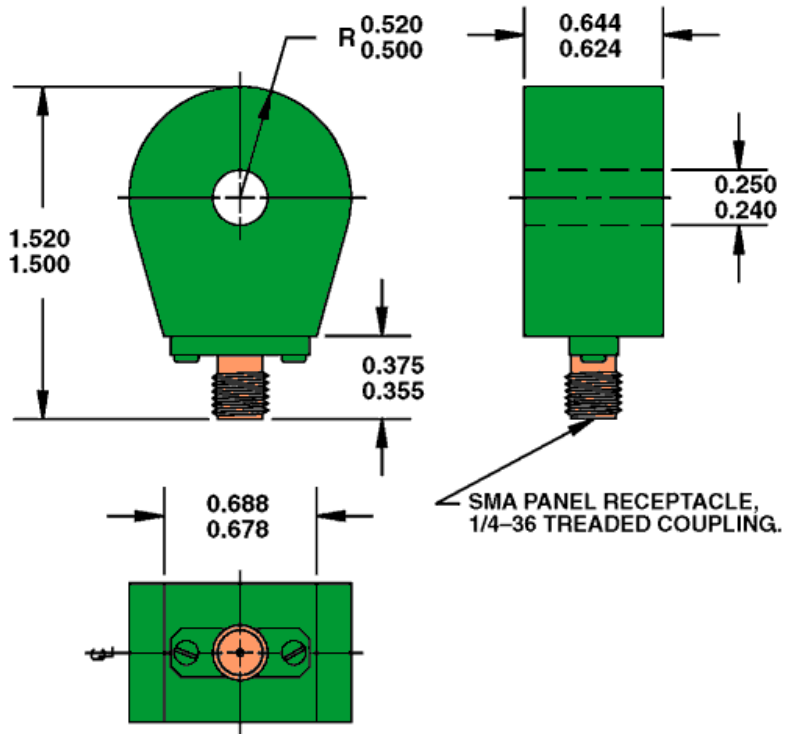

Figure 10: Pearson Electronics Current Monitor. Model 2877