

## DSG RICH R&D Meeting Minutes

**Date: January 29, 2021**

**Time: 11:00AM – 12:00PM**

*Attendees: Aaron Brown, Brian Eng, George Jacobs, Tyler Lemon, Marc McMullen, and Amrit Yegneswaran*

1. Order submitted for Super Dry dry cabinet
  - 1.1. Cabinet will be delivered in ~4 weeks
  - 1.2. Rotameter will be delivered in ~9 weeks
2. New dry cabinet's nitrogen rotameter connection
  - 2.1. 24 VDC solenoid valve will be used in aerogel fail-safe system
  - 2.2. System diagram and parts list will be sent to Bob Miller for Design Authority request

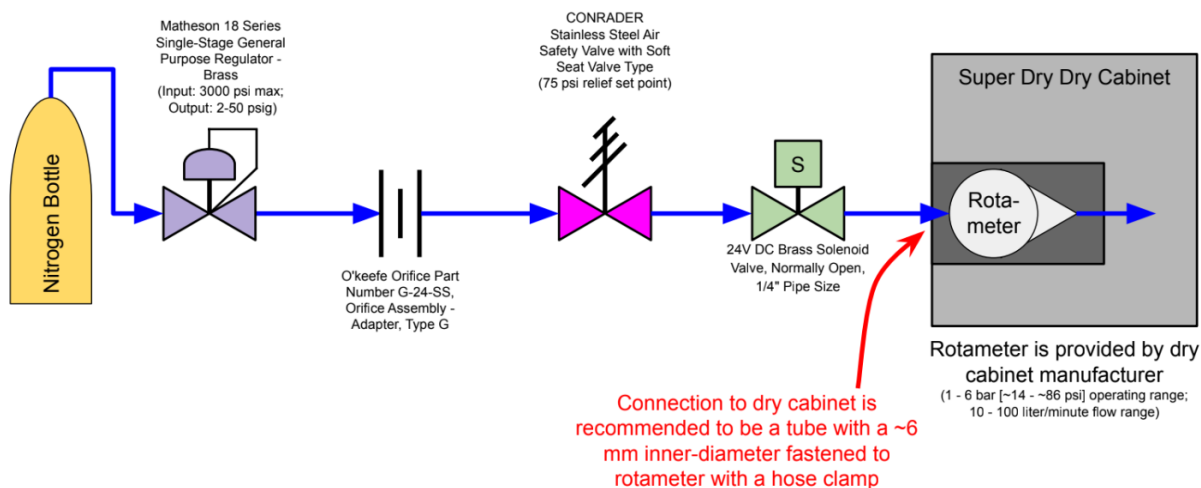

3. Four dry cabinets currently at JLab
  - 3.1. One large XDry cabinet
    - 3.1.1. Does not work; DSG debugging
  - 3.2. Two small XDry cabinets
    - 3.2.1. Works well; filled with aerogel tiles
  - 3.3. One small Super Dry cabinet
    - 3.3.1. Leaky
    - 3.3.2. Brought from Italy by INFN collaborators

#### 4. RICH Sector 1 interlock system development

##### 4.1. Flat cable has smaller cross section than round cables, allowing more cables per square inch

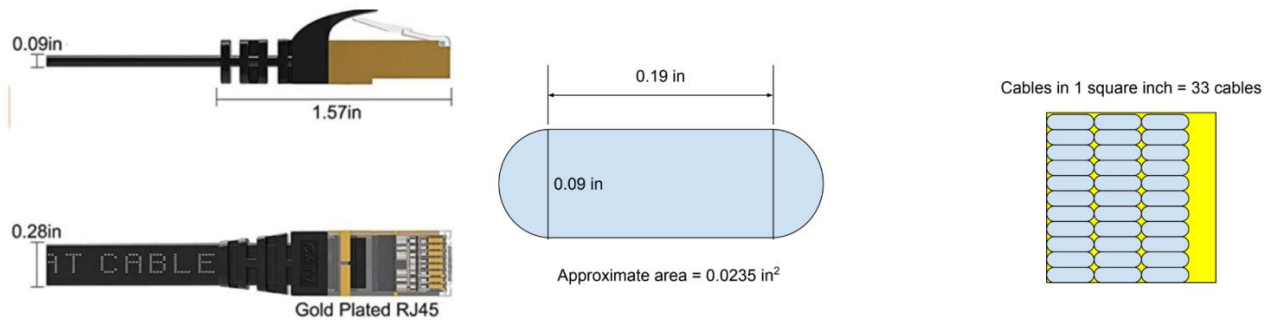

Flat Cat7 cable. Cable in diagram is pre-assembled. Packing density of cable is 33 cables in 1 square inch.

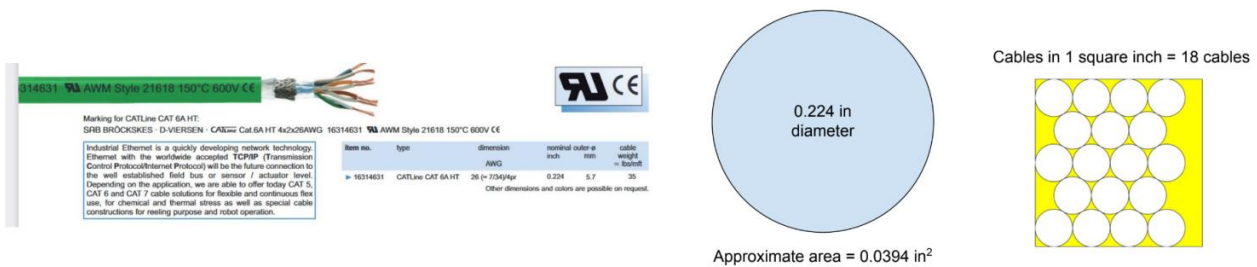

Round Cat6a cable. Cable comes in bulk spools. Packing density of this cable is 18 cables in 1 square inch.

##### 4.2. Reviewed items needed to work on SHT-35 sensor development

Manufacturer Part Number	Source	Description	Quantity	Unit Price	Total Price
SHT35-DIS-F2.5KS	Digi-key	SHT-35 sensor with protective membrane over sensor port	150	\$6.16	\$924.00
ST-203	Digi-key	RJ45 BREAKOUT BOARD	12	\$7.49	\$67.41
MIKROE-2315	Digi-key	Dupont wires for prototyping	3	\$4.40	\$13.20
PCA9515BDGKR	Digi-key	I2C buffer option 1 - single line to/from	10	\$1.43	\$14.33
PA0042	Digi-key	VSSOP-8 TO DIP-8 SMT ADAPTER	10	\$3.19	\$31.90
IPC0061	Digi-key	DFN-8 TO DIP-12 SMT ADAPTER	11	\$5.29	\$58.19
BB-32656	Digi-key	BREADBOARD TERM STRIP 6.50X2.15"	3	\$7.32	\$21.96
PCA9600DP	Digi-key	I2C buffer option 2 - SDA/SCL in differential pairs	12	\$3.75	\$45.00
PA0032	Digi-key	TSSOP-8 TO DIP-8 SMT ADAPTER	12	\$3.19	\$38.28
N/A	Amazon	100 ft flat Cat7 cable	6	\$23.99	\$143.94
CFROW4JE006KIL	Newark	Resistor Kit	1	\$30.27	\$30.27
				<b>TOTAL</b>	<b>\$1,388.48</b>