

He-Cd Laser



IK Series He-Cd Laser : 325nm(UV), 442nm(Blue) and Dual Wavelength

KIMMON KOHA, the world's oldest and largest manufacturer of Helium Cadmium lasers, currently offers 18 models of IK Series 325nm laser, 10 models of IK Series 442nm laser, and 10 models of IK Series Dual Wavelength laser. Over 40 years of HeCd laser manufacturing experience allows KIMMON KOHA to provide HeCd lasers with the highest polarized output power, average lifetime, and reliability. This superior performance over the past 4 decades along with the best warranty available has resulted in KIMMON KOHA having the largest worldwide installed base of HeCd lasers.

KIMMON KOHA's HeCd lasers are used in various applications, some of which are listed below. Please contact your nearest KIMMON KOHA office or distributors for assistance in selecting the proper laser model for your applications.

APPLICATION

- Photoluminescence
- Raman Spectroscopy
- Biomedicine/Bioengineering
- Flow Cytometry
- Lithography/Grating Production
- Photopolymer Exposure
- Interferometry
- Printing/Plate making
- Precision measurement
- Holography
- Defect inspection

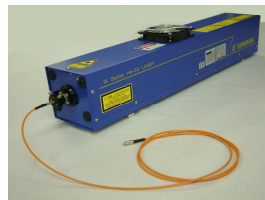

SPECIFICATIONS

325nm Lasers

Model	Wavelength (nm)	Power (mW)	Transverse Mode	Polarization	Polarization Ratio	Beam Diameter $1/e^2$ (mm) ^{*1}	Beam Divergence (mrad) ^{*2}	Noise P-P, @30kHz ~ 2MHz (%) ^{*2}	Noise RMS, @30kHz ~ 10MHz (%) ^{*2}
IK3023R-BR	325	2	TEM ₀₀	Random	N/A	< 0.9	< 0.6	< 8	< 2.0
IK3052R-BR		5	TEM _{multi mode}			< 1.5	< 0.8		
IK3031R-C		4	TEM ₀₀			< 1.0	< 0.4		
IK3072R-C		7	TEM _{multi mode}	< 1.8	< 1.0				
IK3083R-D		8	TEM ₀₀	< 1.0	< 0.4				
IK3101R-D		10		< 0.5					
IK3152R-D		15	TEM _{multi mode}	< 1.6	< 1.0				
IK3202R-D		25		< 1.2	< 0.4				
IK3151R-E		15	TEM ₀₀	< 1.8	< 1.0				
IK3252R-E		30	TEM _{multi mode}	> 500:1	Linear	< 1.2	< 0.4	< 10	< 3.0
IK3201R-F		20	TEM ₀₀			< 1.8	< 1.0		
IK3401R-F		40	TEM ₀₀			< 1.2	< 0.4		
IK3452R-F		45	TEM _{multi mode}	< 1.8	< 1.0				
IK3301R-G		30	TEM ₀₀	< 1.2	< 0.5				
IK3501R-G		50		< 1.5	< 1.0				
IK3552R-G		55	TEM _{multi mode}	< 1.2	< 0.5				
IK3802R-G		80		< 1.8	< 1.0				
IK3102R-G	100	< 1.8		< 1.0					

442nm Lasers

Model	Wavelength (nm)	Power (mW)	Transverse Mode	Polarization	Polarization Ratio	Beam Diameter $1/e^2$ (mm) ^{*1}	Beam Divergence (mrad) ^{*2}	Noise P-P, @30kHz ~ 2MHz (%) ^{*2}	Noise RMS, @30kHz ~ 10MHz (%) ^{*2}
IK4123R-B	442	14	TEM ₀₀	Linear	> 500:1	< 0.9	< 0.5	< 5	< 2.0
IK4153R-C		20				< 1.0			
IK4151R-C		25				< 1.1			
IK4301R-D		30				< 1.2	< 0.4	< 15	< 4.0
IK4401R-D		50							
IK4601R-E		70				< 1.4	< 0.5	< 20	< 5.0
IK4101R-F		100							
IK4121R-G		125							
IK4131I-G		150							
IK4171I-G		180							

Dual Wavelength Lasers

Model	Wavelength (nm)	Power (mW)	Transverse Mode	Polarization	Polarization Ratio	Beam Diameter $1/e^2$ (mm) ^{*1}	Beam Divergence (mrad) ^{*2}	Noise P-P, @30kHz ~ 2MHz (%) ^{*2}	Noise RMS, @30kHz ~ 10MHz (%) ^{*2}
IK5351R-D	325/442	5/35	TEM ₀₀	Linear	> 500:1	< 0.9/1.0	< 0.5	< 10/10	< 2.0/2.0
IK5352R-D		10/50	TEM _{multi mode}			< 1.3/1.3	< 1.0		
IK5451R-E		10/50	TEM ₀₀			< 1.0/1.1	< 0.5		
IK5452R-E		15/65	TEM _{multi mode}			< 1.3/1.3	< 1.0		
IK5551R-F		15/60	TEM ₀₀			< 1.1/1.2	< 0.5		
IK5552R-F		25/100	TEM _{multi mode}			< 1.5/1.5	< 1.0		
IK5651R-G		20/80	TEM ₀₀			< 1.2/1.2	< 0.5		
IK5652R-G		30/120	TEM _{multi mode}			< 1.8/1.8	< 1.0		
IK5751I-G		30/110	TEM ₀₀			< 1.2/1.2	< 0.5		
IK5752I-G		40/150	TEM _{multi mode}			< 1.8/1.8	< 1.0		



Common Specifications

Model	Power Stability (%) ^{*3}	Warm Up Time (90% Power) (minutes) ^{*3}	Laser Class	Weight (kg)
IK****R-B	≤±2.0 (4 hours)	15	3B / IIIb	8.5
IK****R-C				11.0
IK****R-D		20		16.0
IK****R-E				17.0
IK****R-F				19.0
IK****R(D)-G				23.5

Power Supply

Model	Input Voltage (V)	Weight (kg)
KP2014C	100~240	8.0

Details by form

Head Model	Maximum Current (A)	Power Consumption (W)
IK****R-B	< 4.0	< 350
IK****R-C	< 4.2	< 480
IK****R-D	< 5.5	< 500
IK****R-E	< 7.0	< 610
IK****R-F	< 7.5	< 660
IK****R(D)-G	< 8.0	< 720

*1 Measured at 100mm from output coupler

*2 By the measuring method of our company

*3 At 25°C Constant Temperature

* Environmental Condition (Operation) Temperature 10~40°C, Humidity ≤90%RH

* Environmental Condition (Storage) Temperature -10~50°C, Humidity ≤90%RH

* Non-condensing

* Specifications subject to change without notice.



Dimensions (mm)

Laser Head

IK-B TYPE

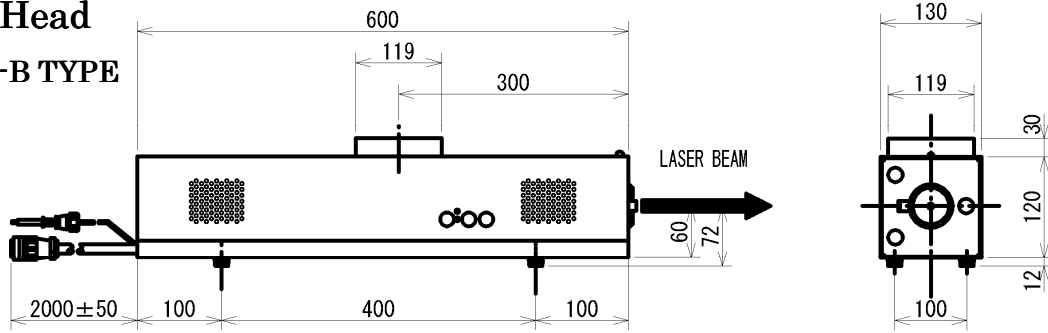

IK-C TYPE

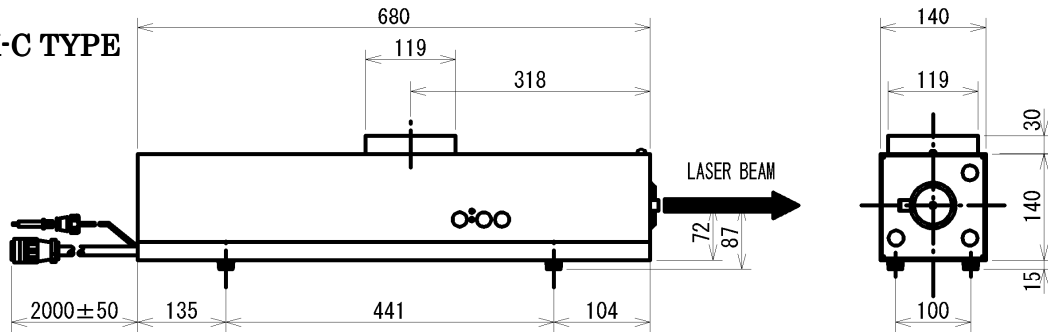

IK-D~G TYPE

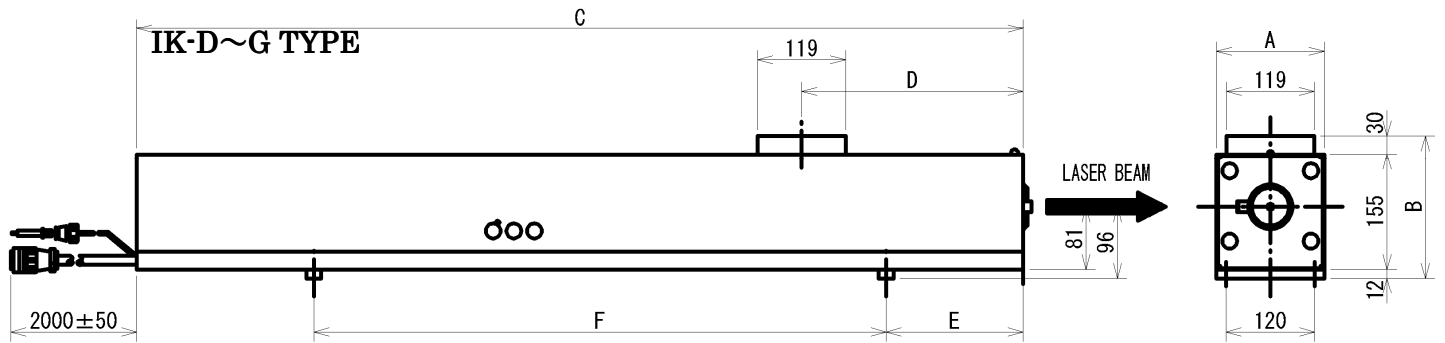

	A	B	C	D	E	F
IK****R-D	146	197	850	380	128	605
IK****R-E	146	197	1020	300	128	775
IK****R-F	146	197	1200	300	353	440
IK****R(I)-G	146	197	1420	461	353	660

Power Supply : KP2014C

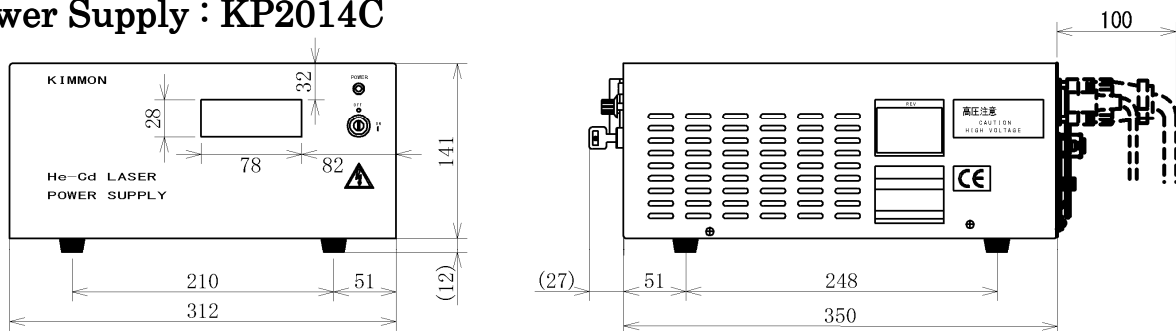

 **KIMMON KOHA CO., LTD.**



Photonic Solutions Ltd Unit 2.2, Quantum Court, Research Avenue South,
 HWU Research Park, Edinburgh, EH14 4AP, UK, Tel: +44 (0)131 664 8122
 Email sales@photonicsolutions.co.uk Web www.photonicsolutions.co.uk