

Assembly procedure of the RICH frontal panels

G.Fuga (LNF)

- 1. Procedure for the assembly of the tool for the installation of the RICH frontal panels**
- 2. Procedure for the preparation of the RICH supporting structure before the installation of the frontal panels**
- 3. Procedure for the installation of the RICH Frontal Panels**

**1. Procedure for the assembly
of the tool for the installation of
the RICH frontal panels**

Assembly of the support - 1

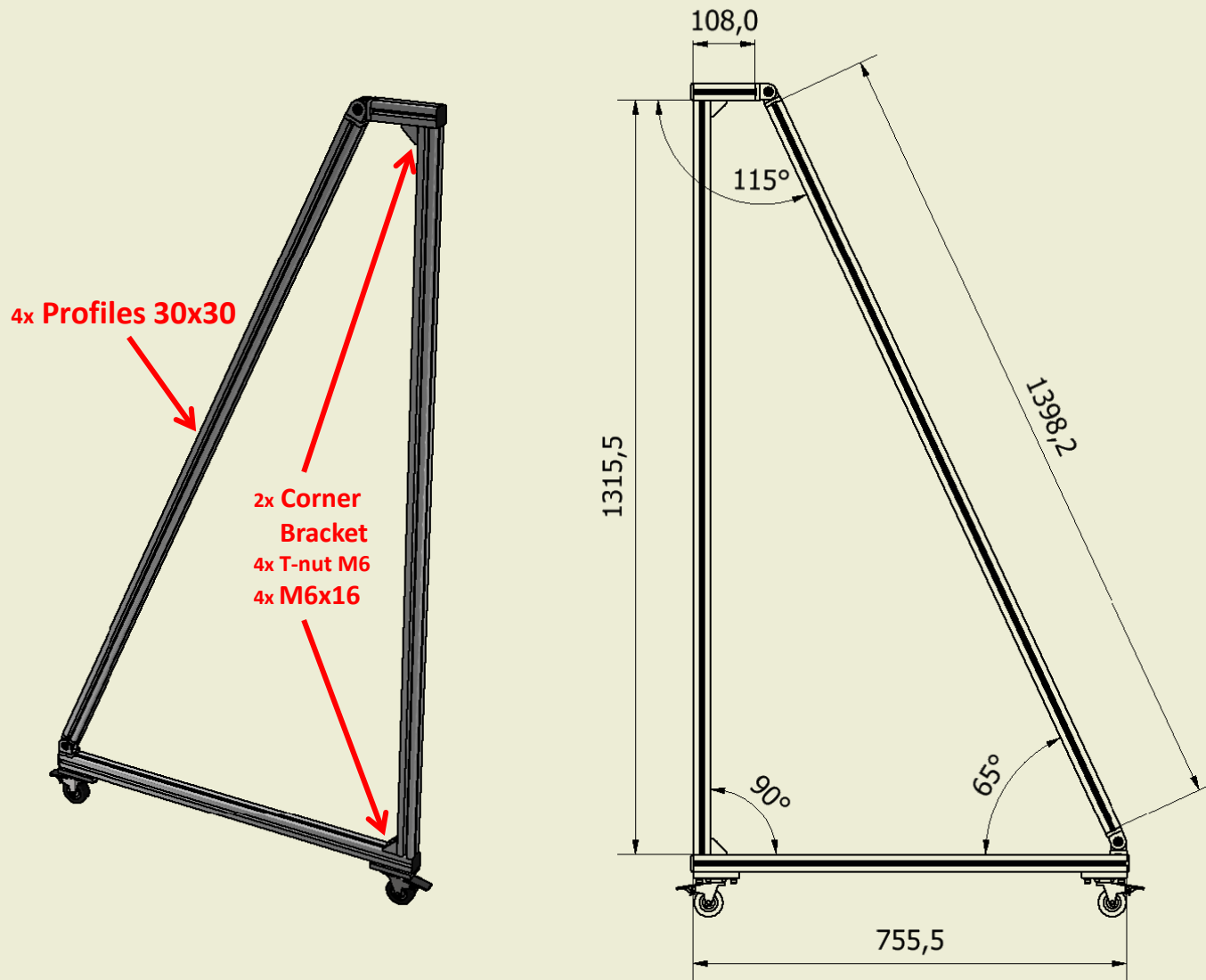

Supporting side (x2)

Assembly of the support - 2

*** Skip the two tabs with a hammer



Tighten the screw after positioning it at the right angle

Multi-angle Bracket
2x M8x25

Plastic end cap

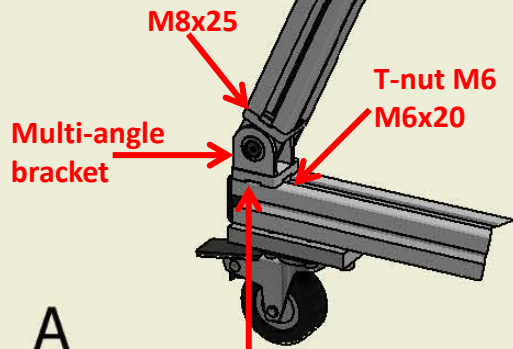

A

A

Wheel mounted on aluminum plate
4x T-nut M6
4x M6x20

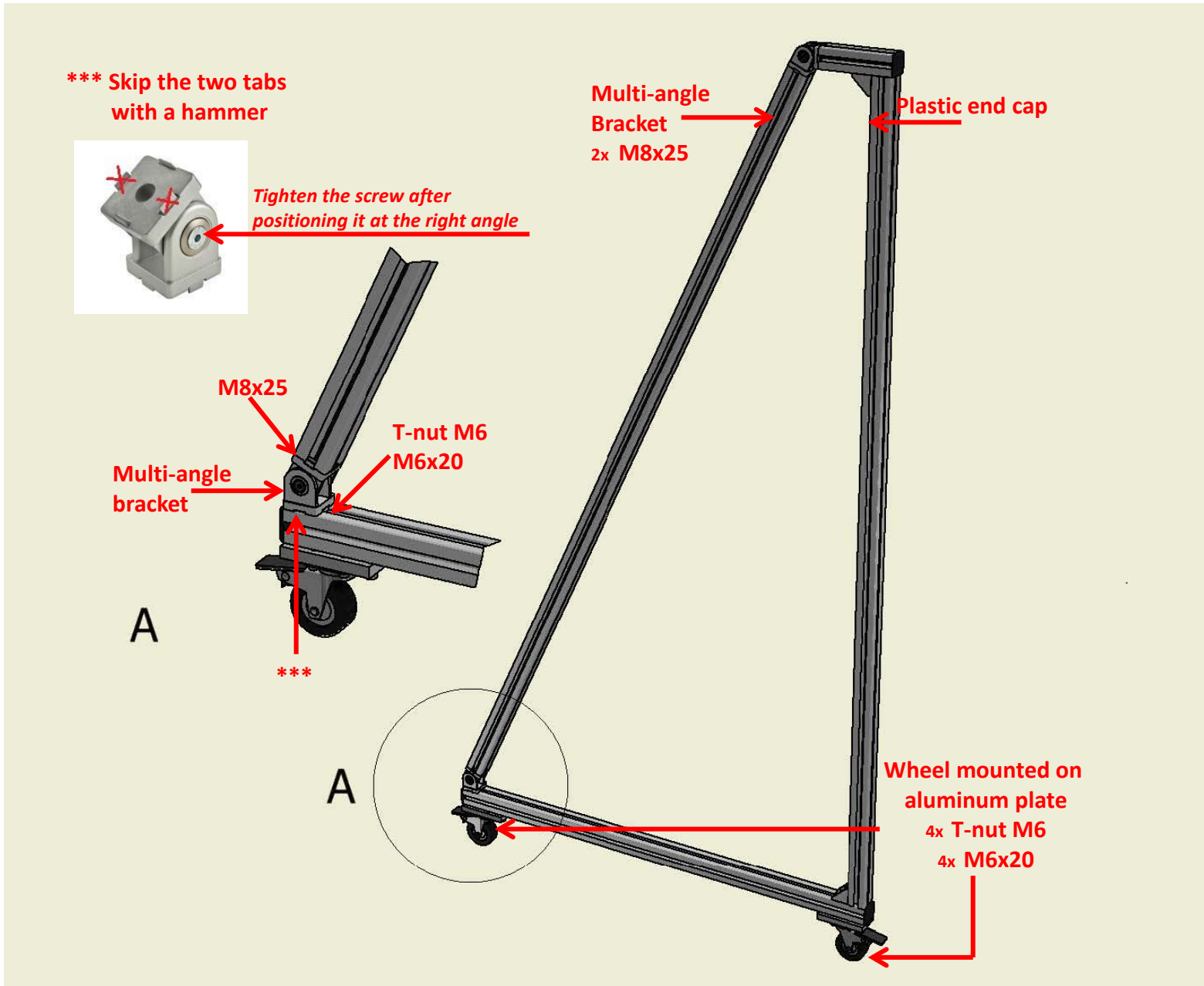

Assembly of the support for Top Front Panel - 1

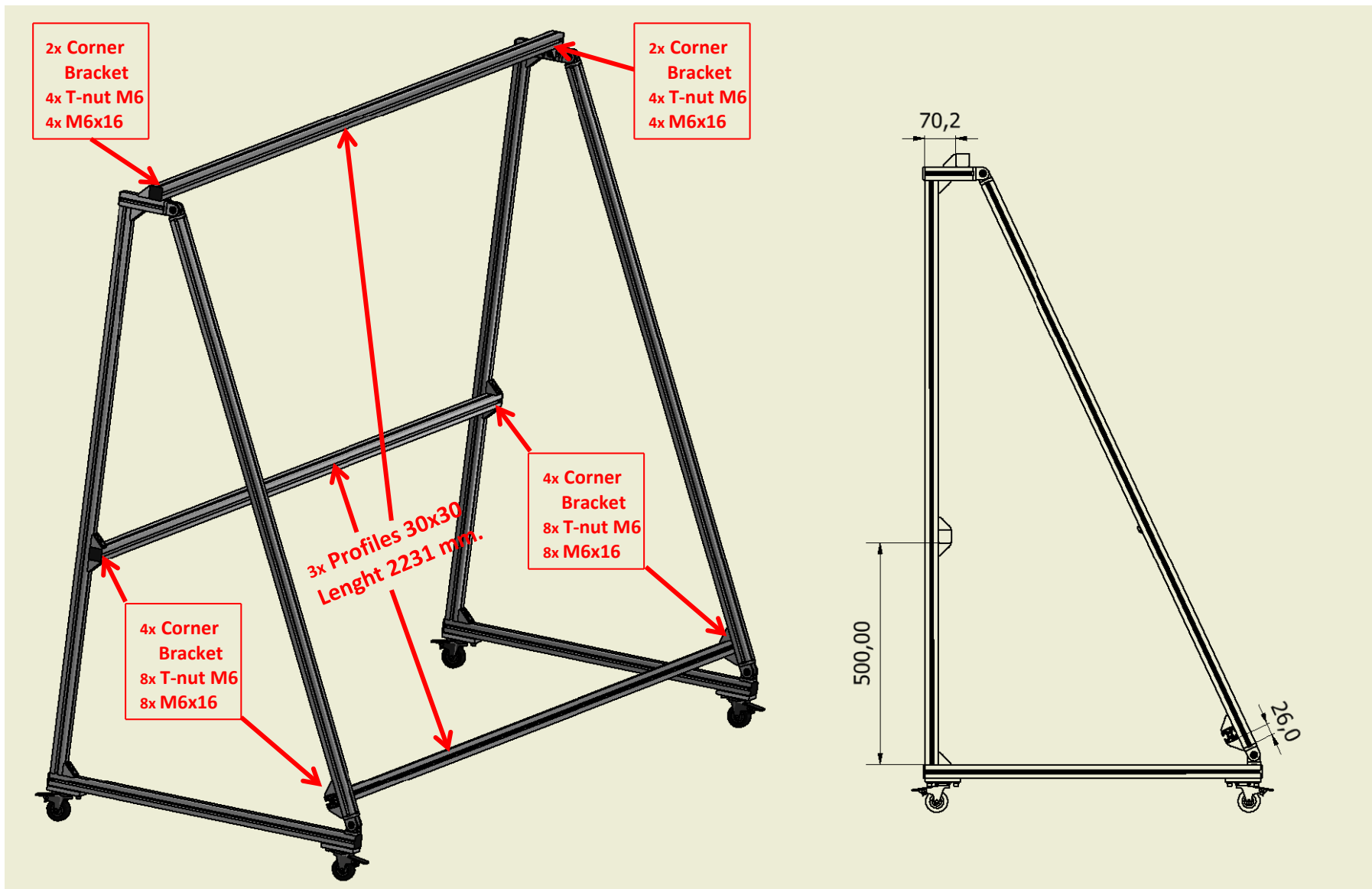

Assembly of the support for Top Front Panel - 2

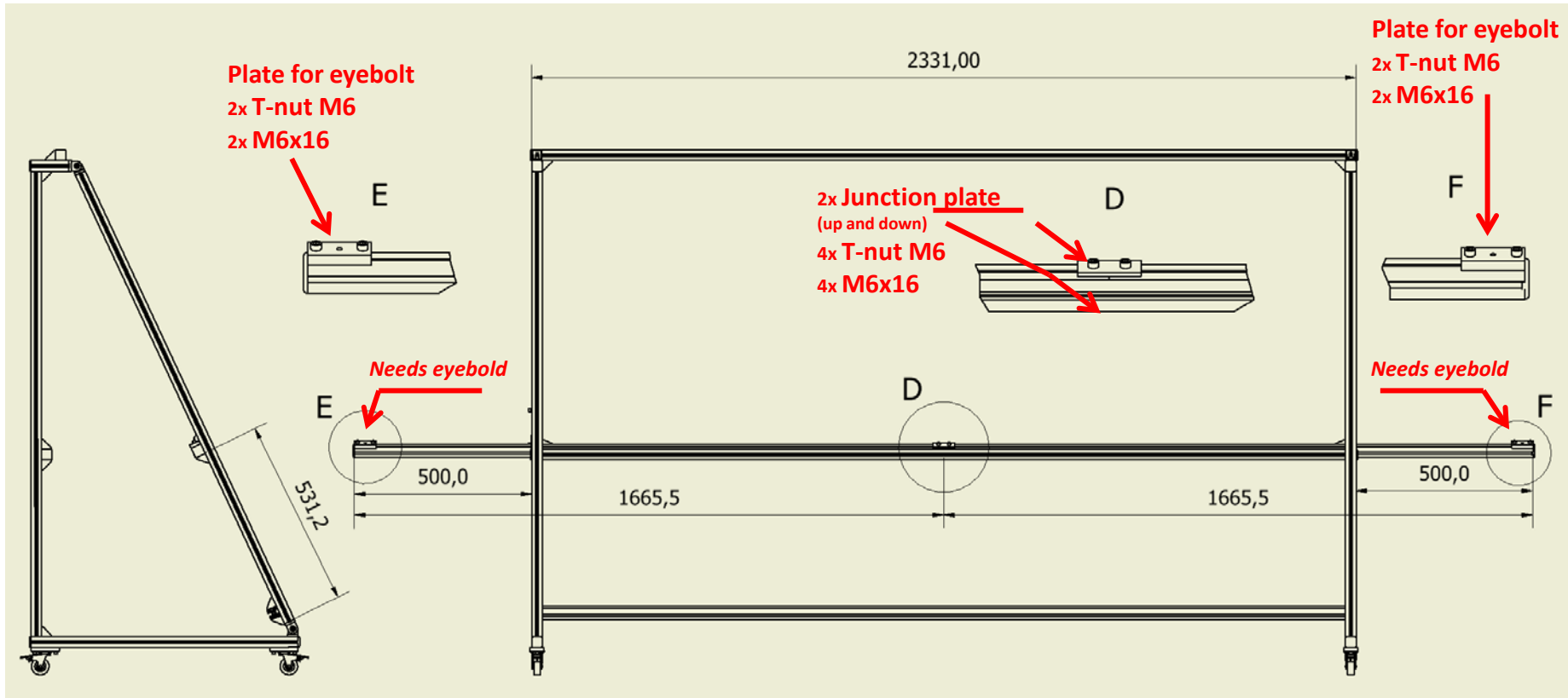
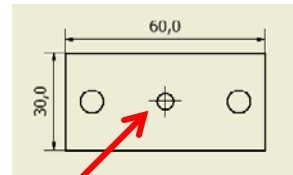
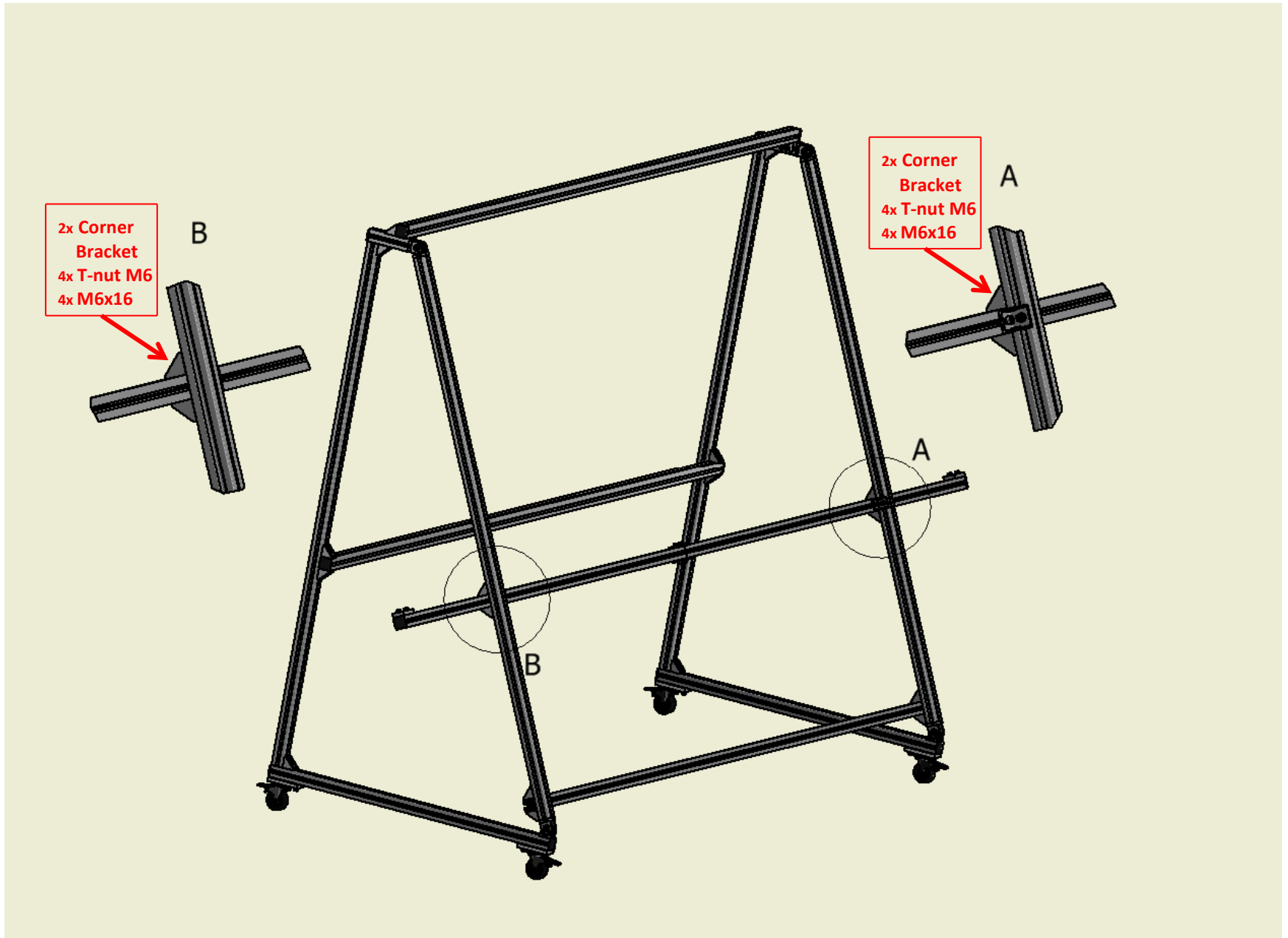

Plate for eyebolt



Needs
Thread 1/4 inch

Assembly of the support for Top Front Panel - 3



Assembly of the support for Top Front Panel - 4

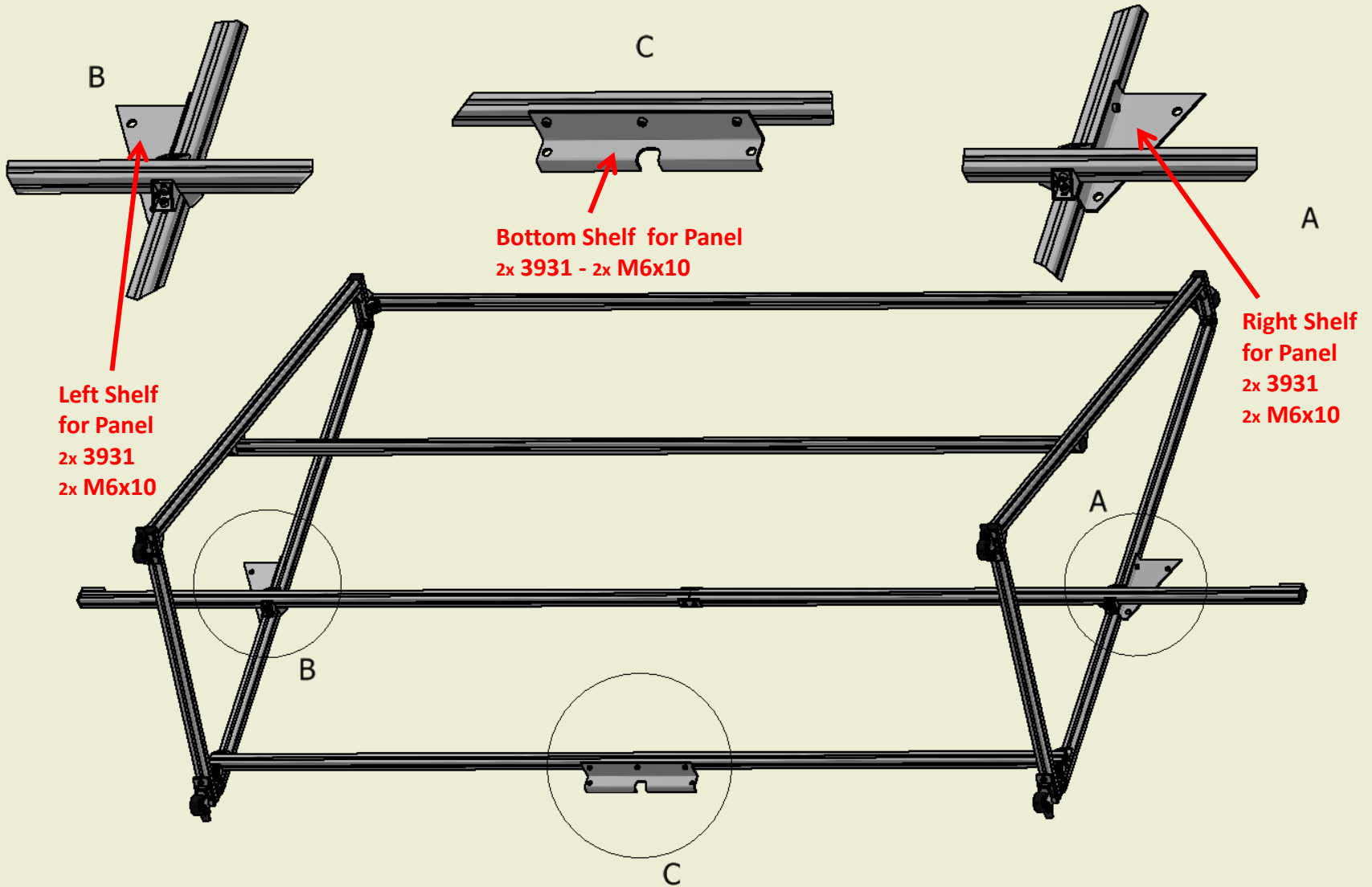

Assembly of the support for Top Front Panel - 5

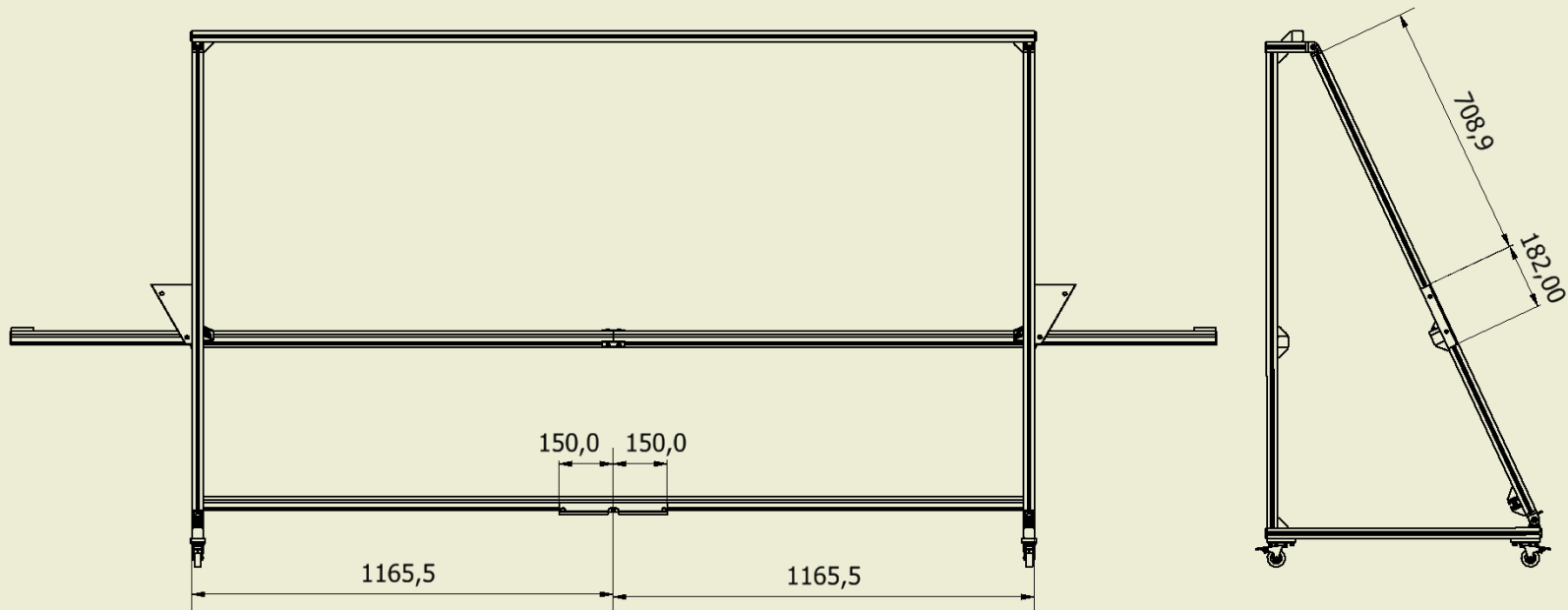

Assembly of the support for Top Front Panel - 6

Top Shelf for Panel
2x 3931 - 2x M6x10

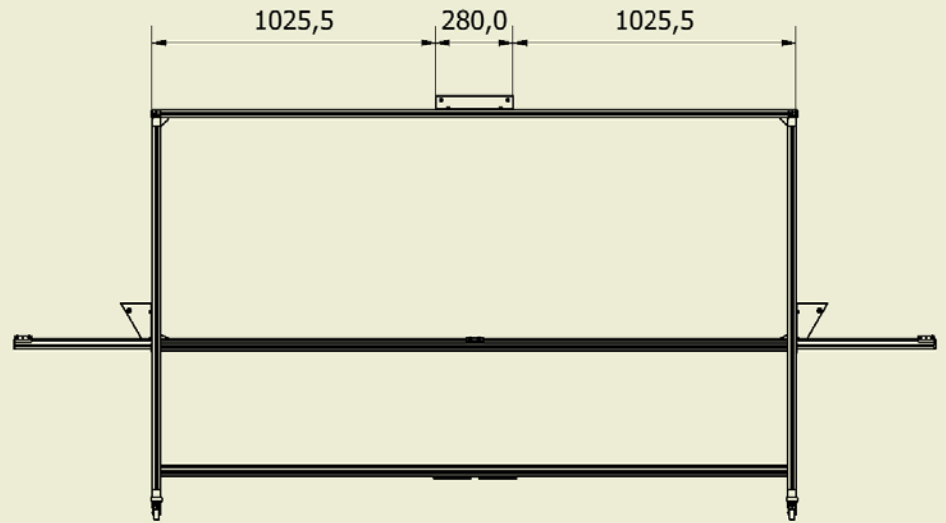
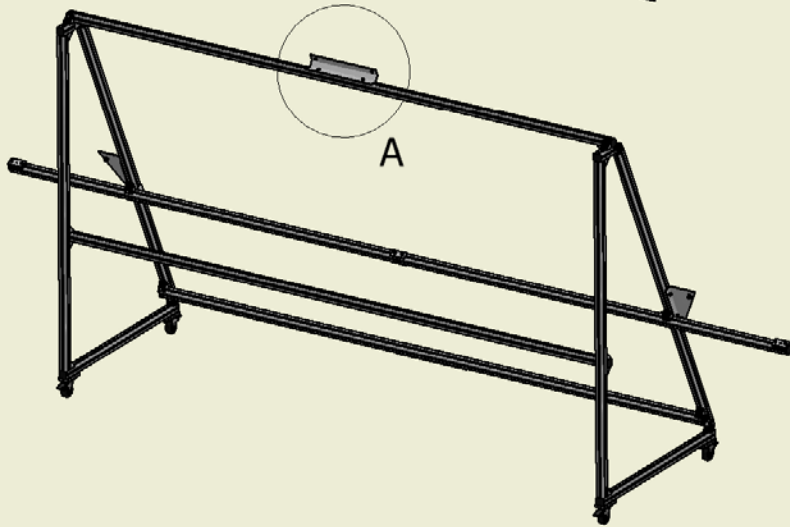
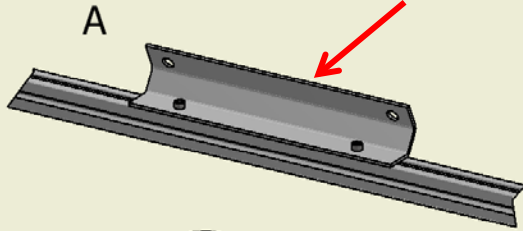

Mounting of the Top Front Panel - 1

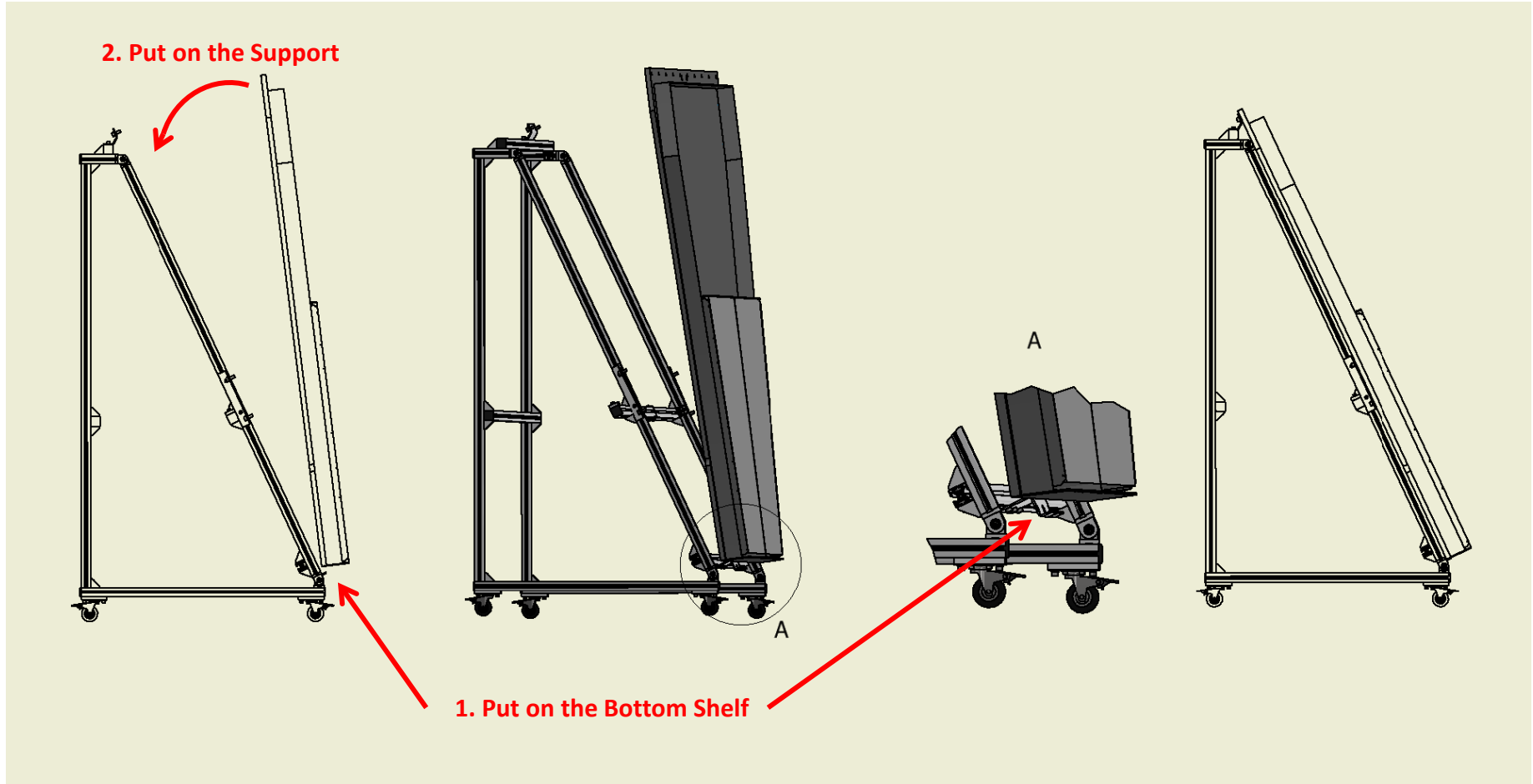

Mounting of the Top Front Panel - 2

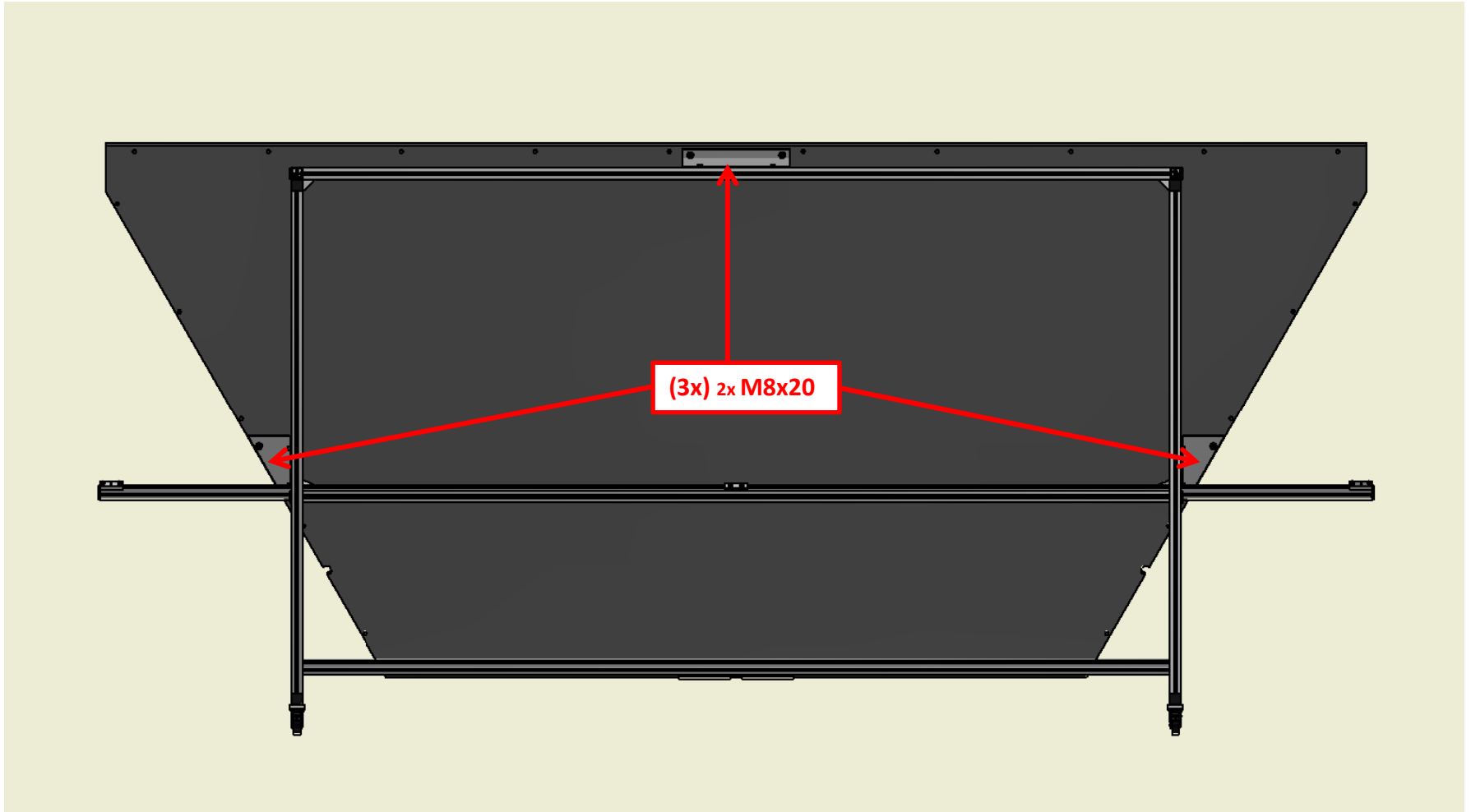

Assembly of the support for Bottom Front Panel

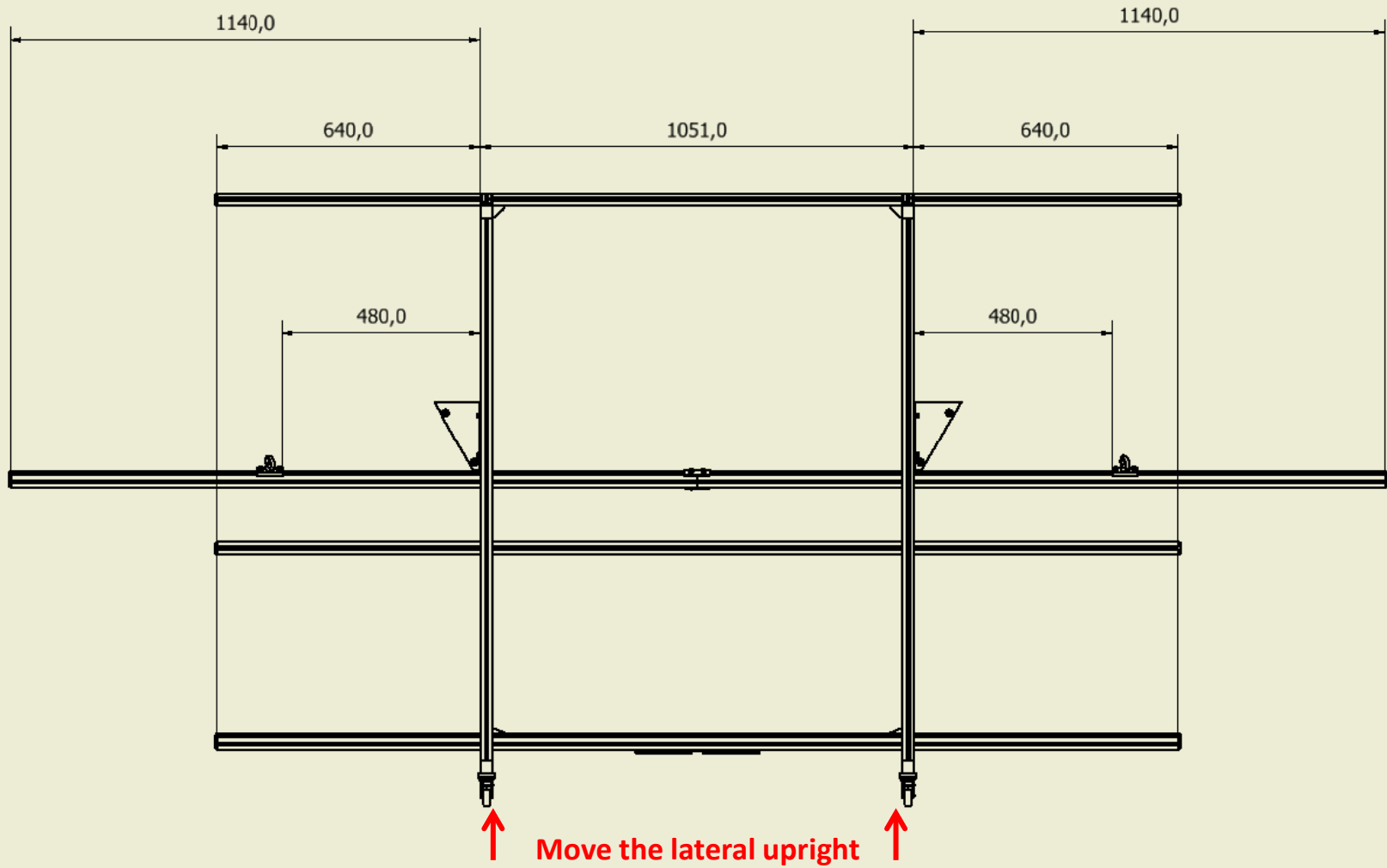

Mounting of the Bottom Front Panel

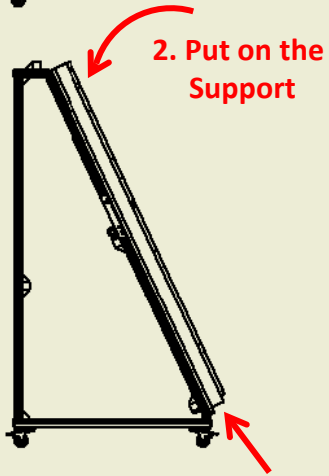
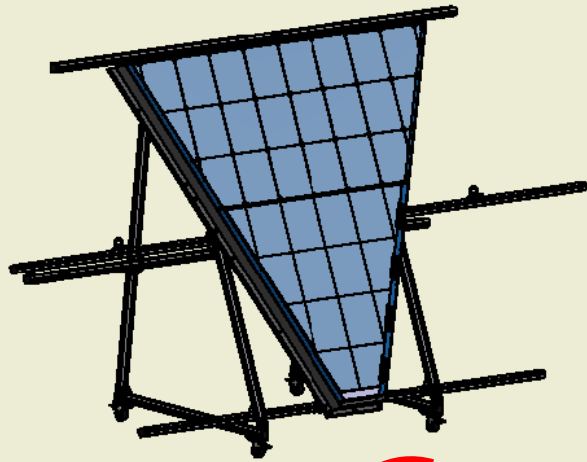

1. Put on the Bottom Shelf

2. Put on the Support

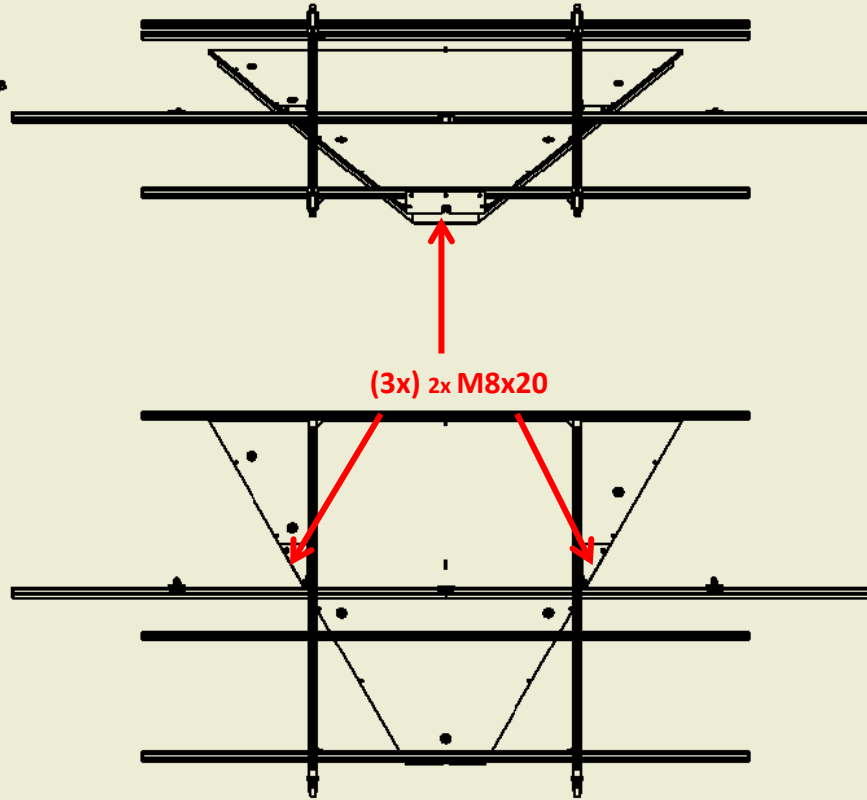

(3x) 2x M8x20

2. Procedure for the preparation of the RICH supporting structure before the installation of the frontal panels

Removing elements

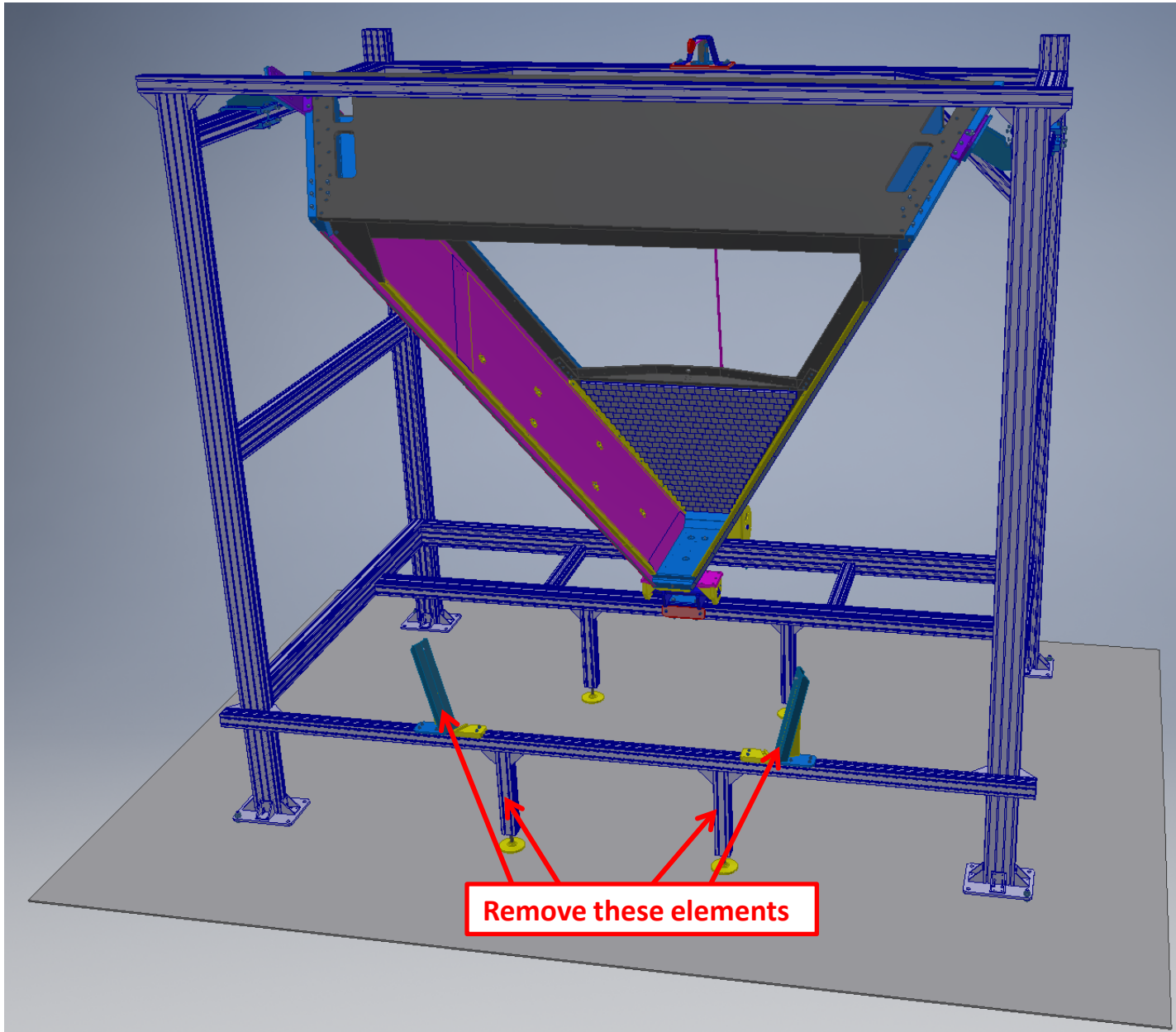

Existing cross bar positioning for the Bottom Front Panel

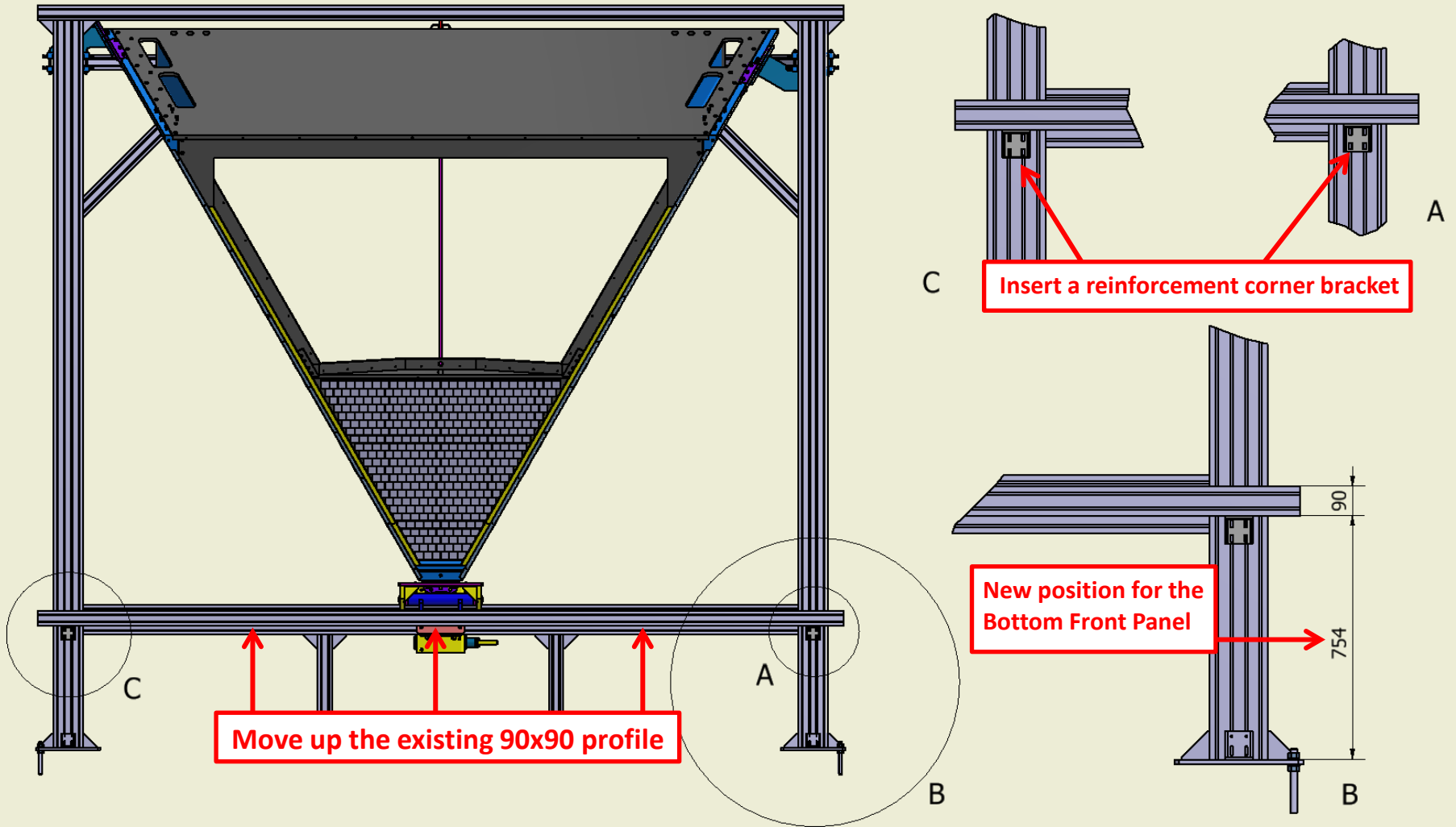

Mounting insert guides for the Bottom Front Panel - 1

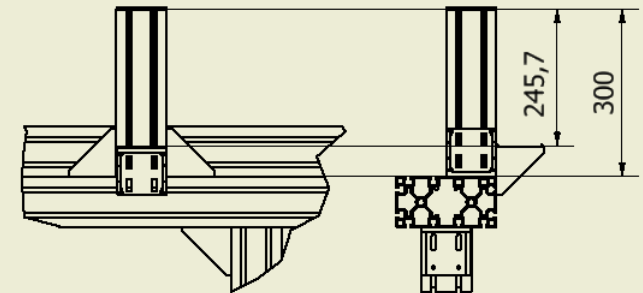
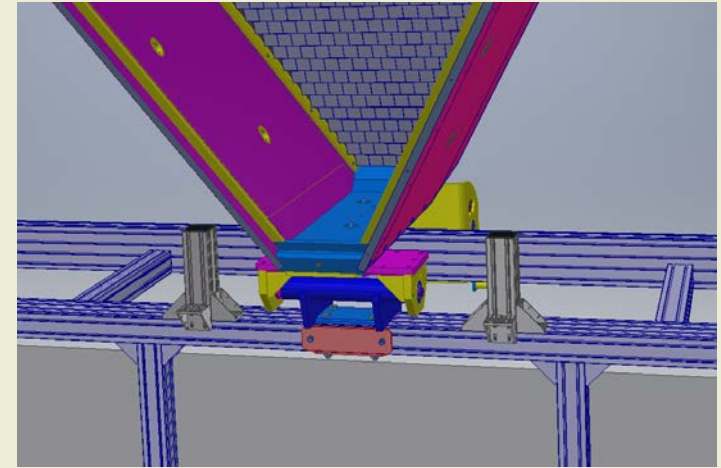
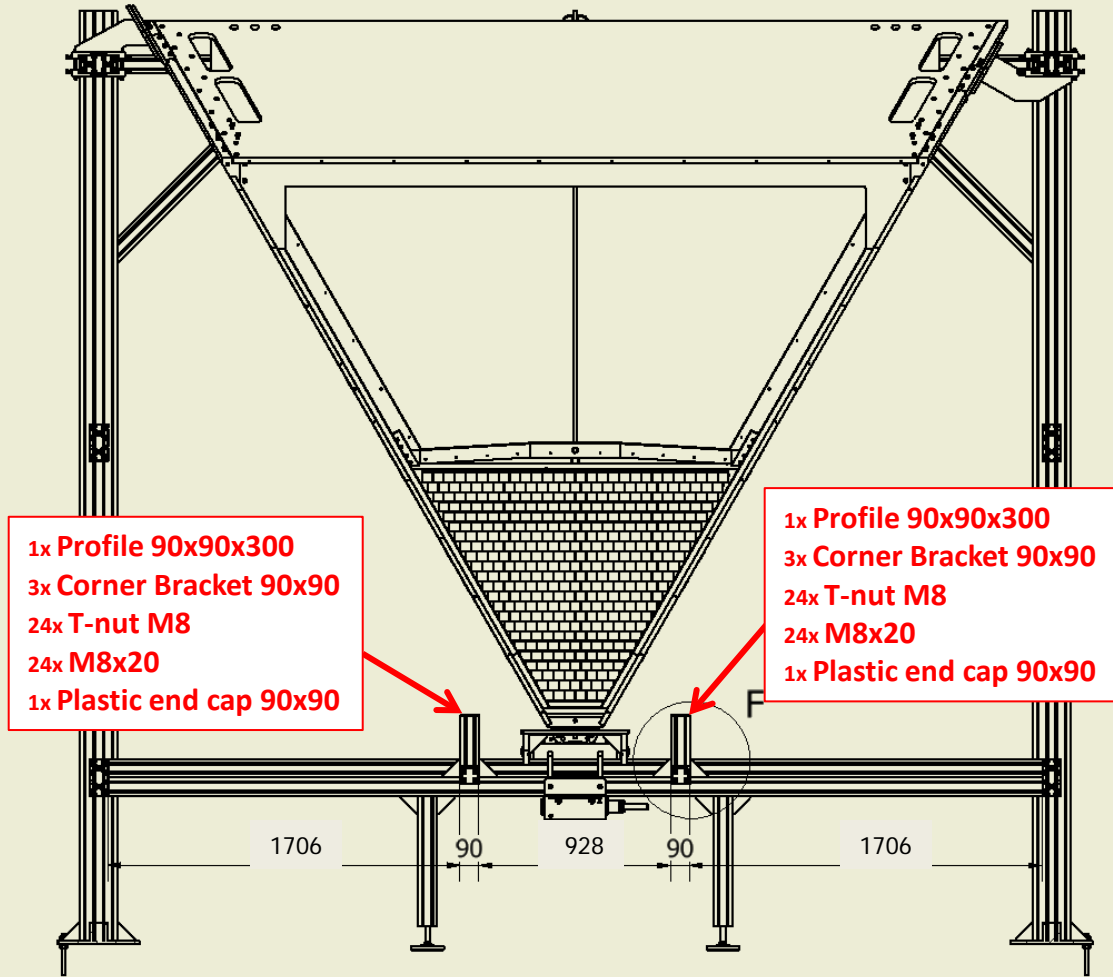

F

Mounting insert guides for the Bottom Front Panel – 2

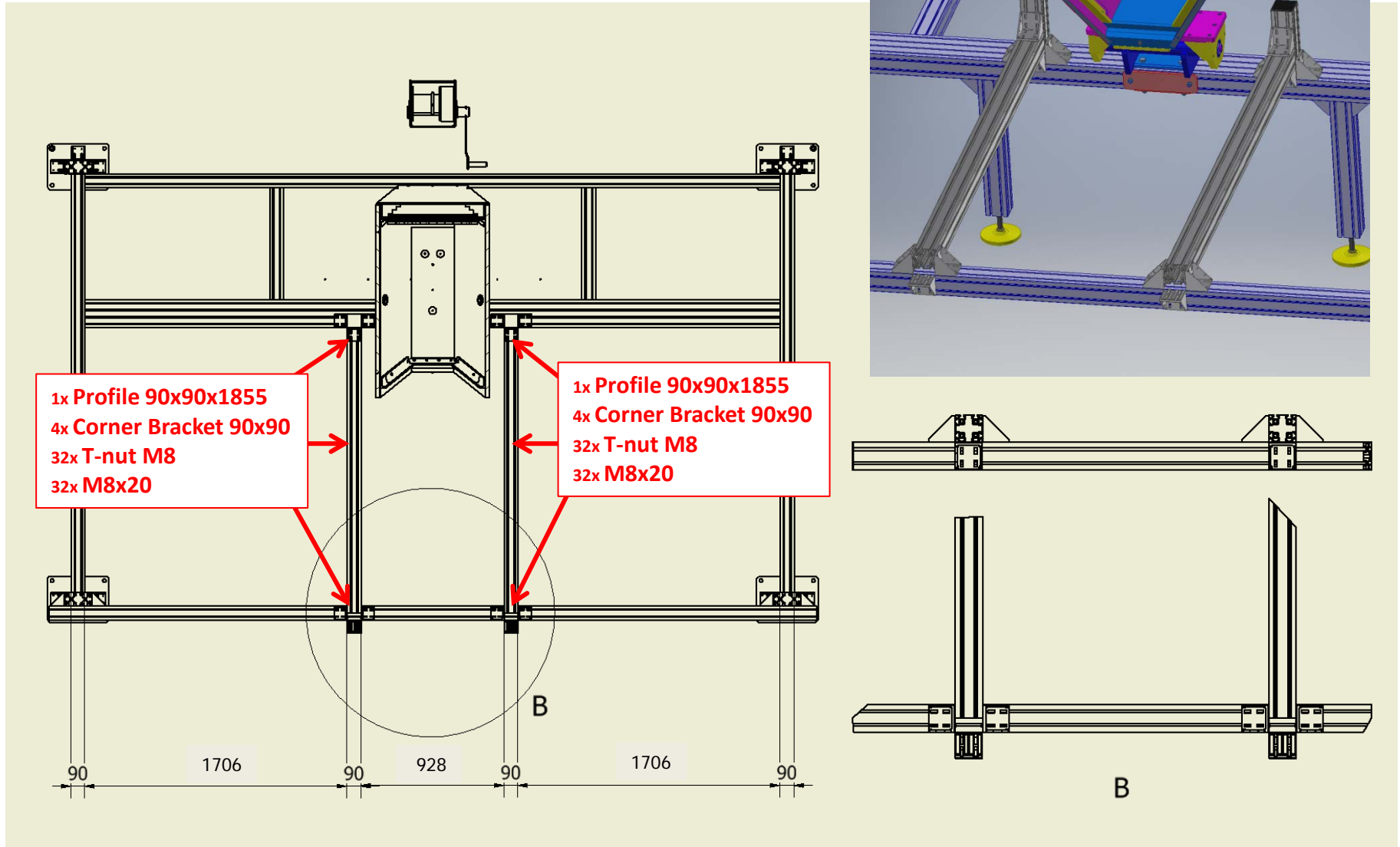

Mounting insert guides for the Bottom Front Panel – 3

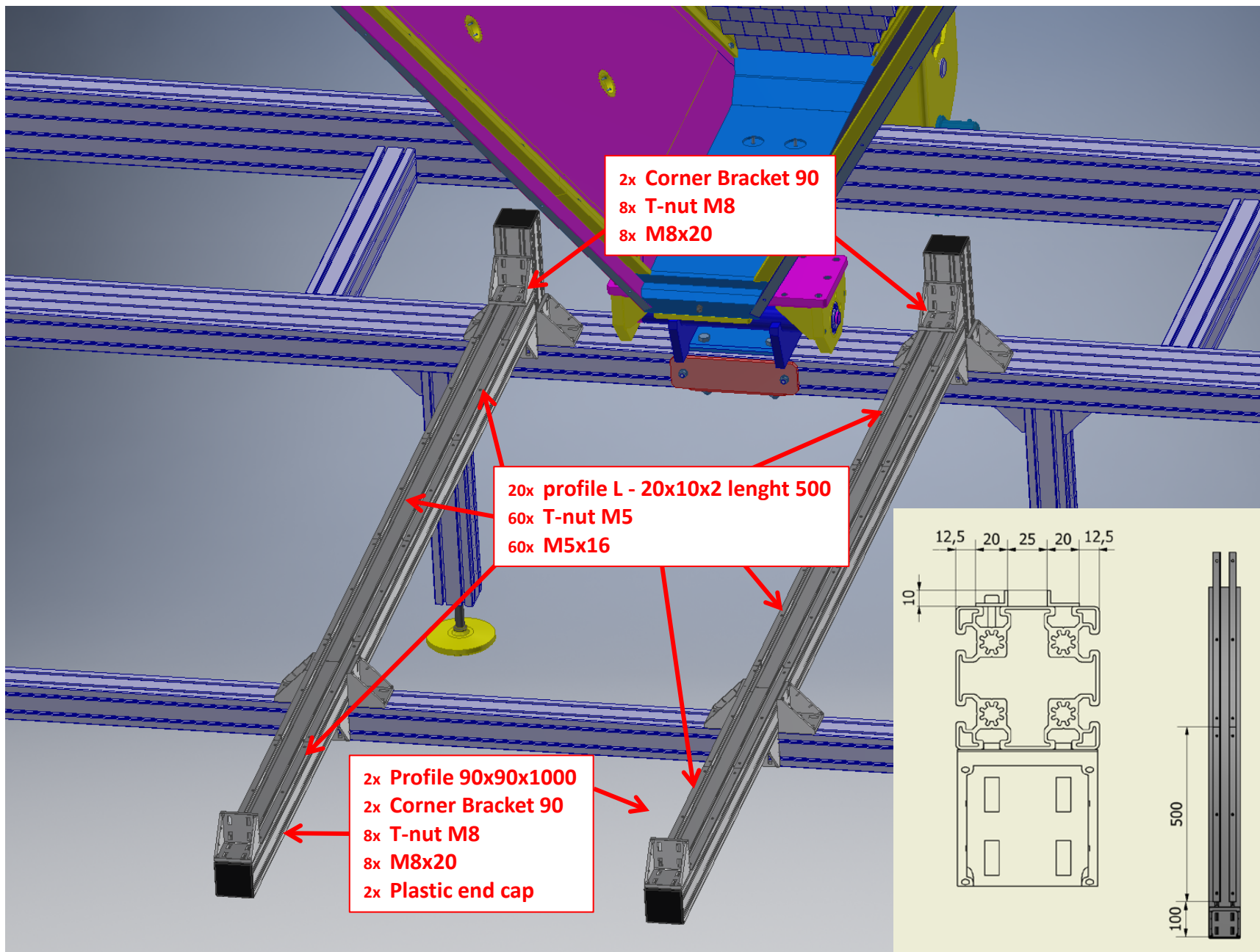

Existing cross bar positioning for the Top Front Panel

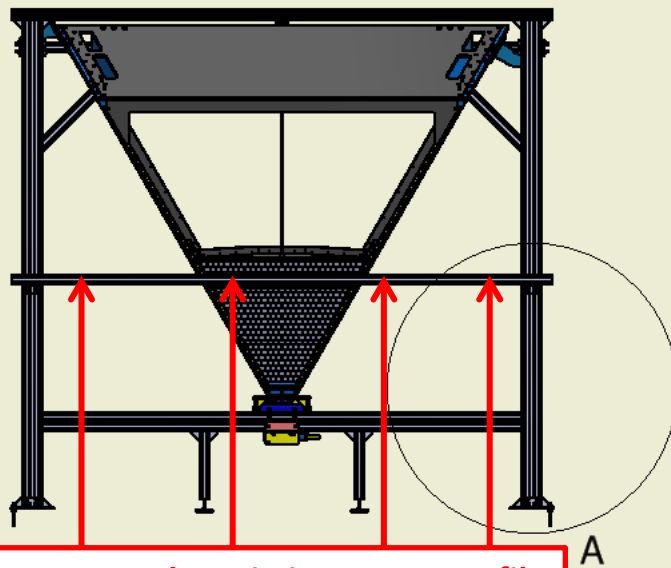

Move up the existing 90x90 profile

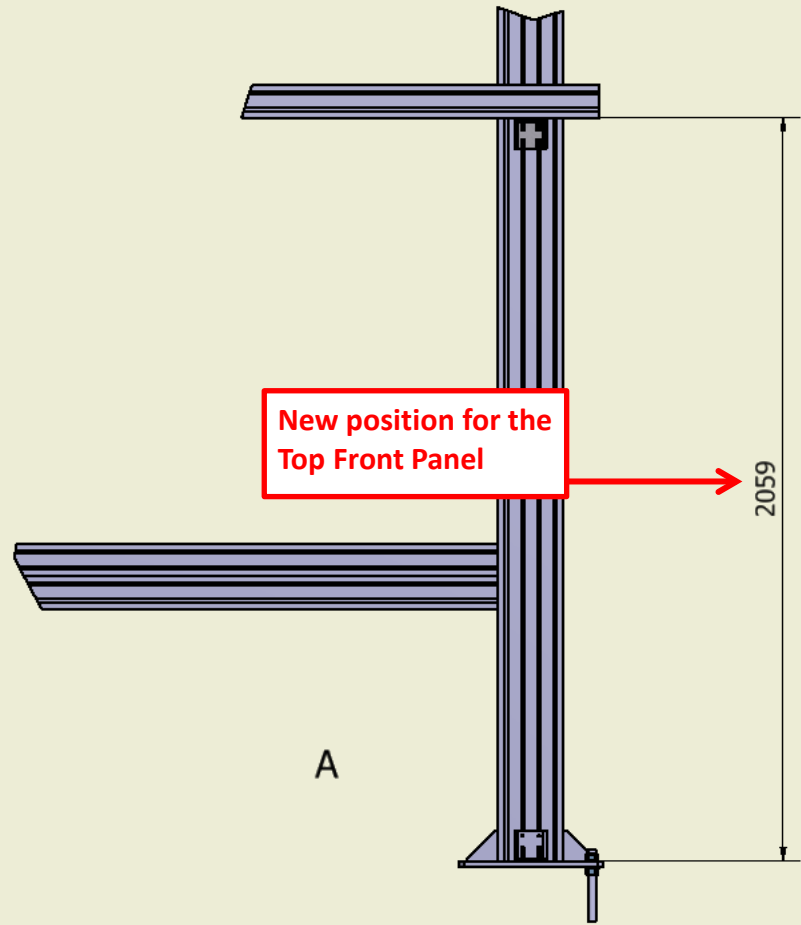

Mounting insert guides for the Top Front Panel - 1

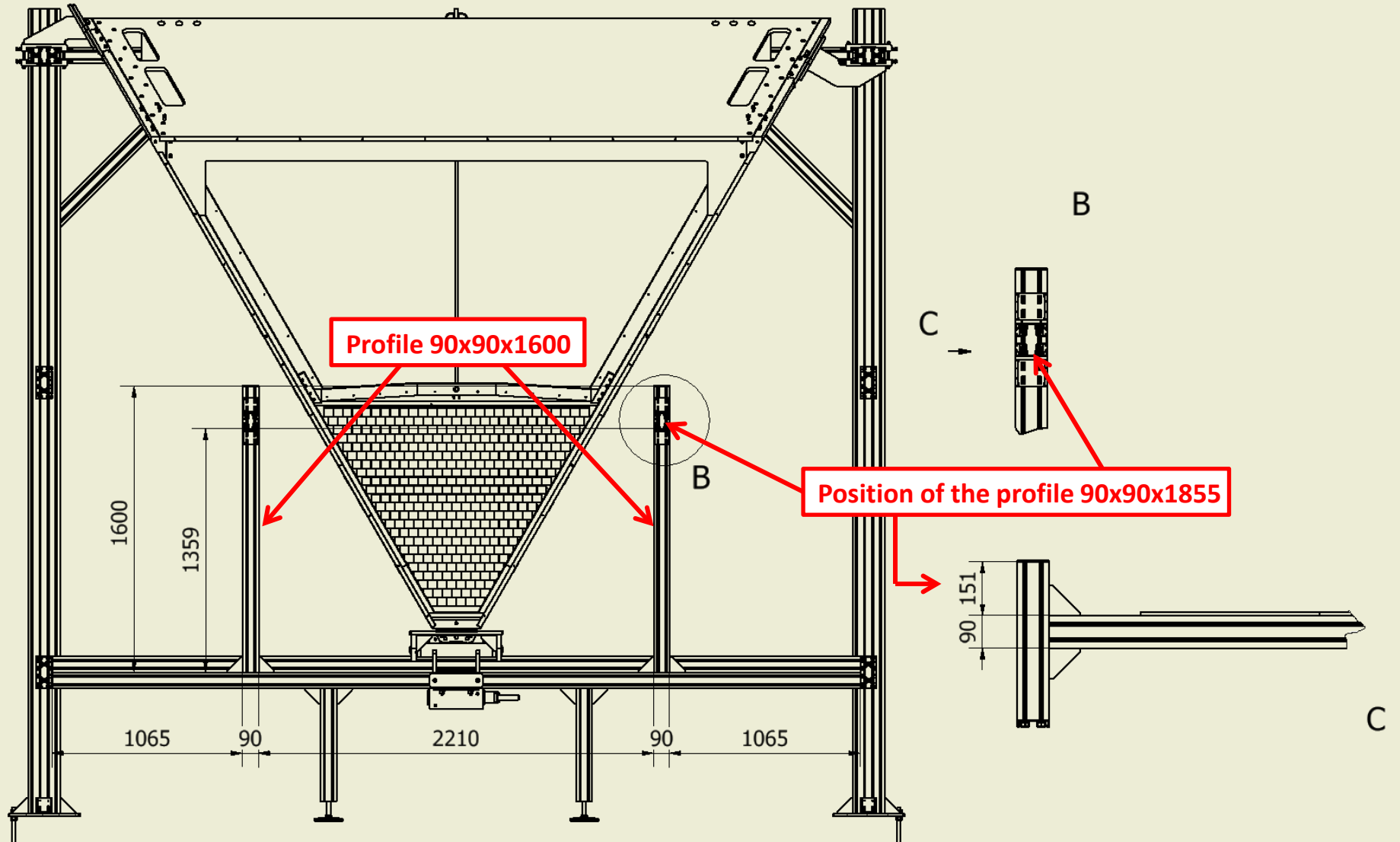

Mounting insert guides for the Top Front Panel - 2

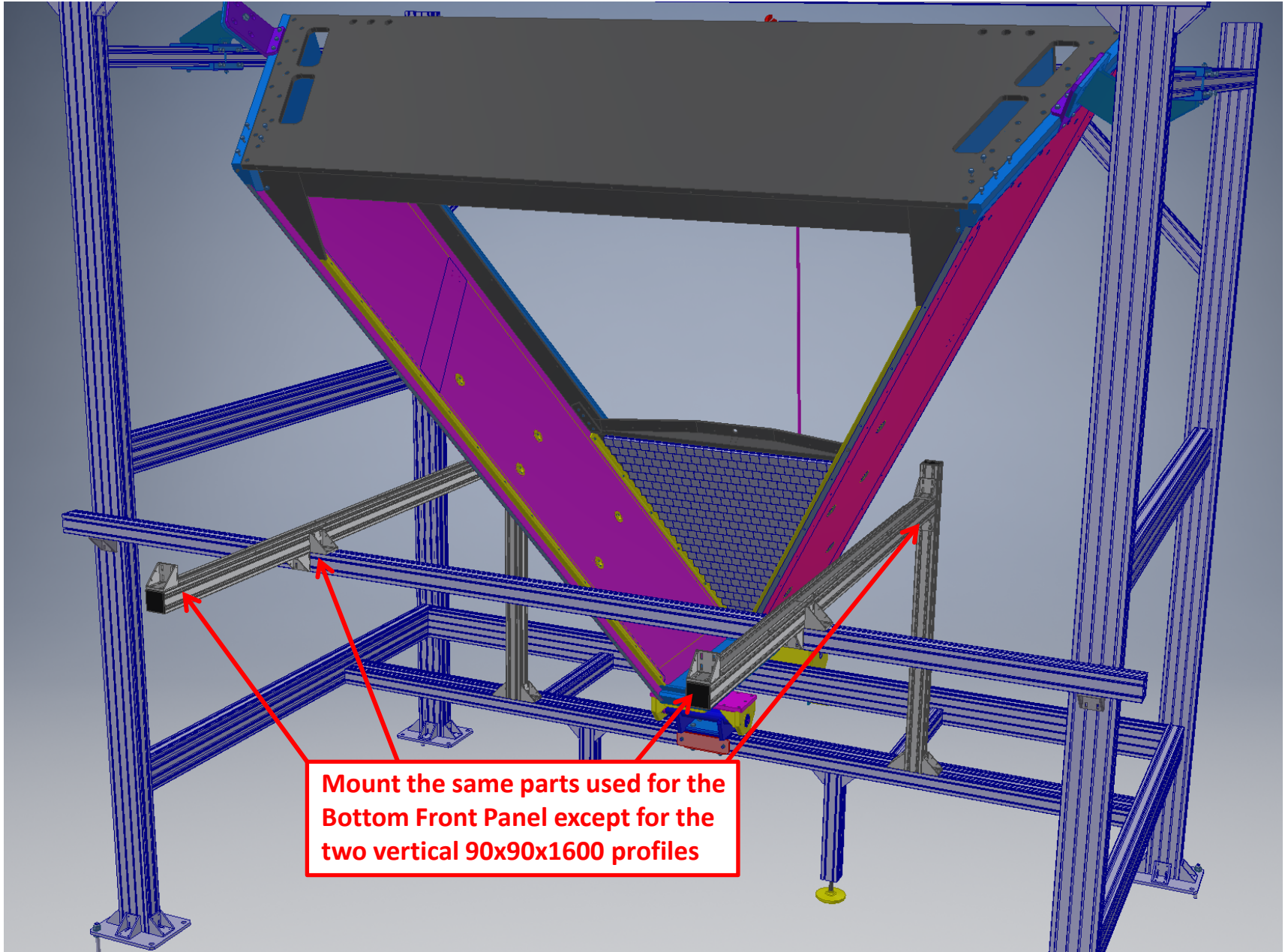

3. Procedure for the installation of the RICH Frontal Panels

Inserting Bottom Front Panel - 1

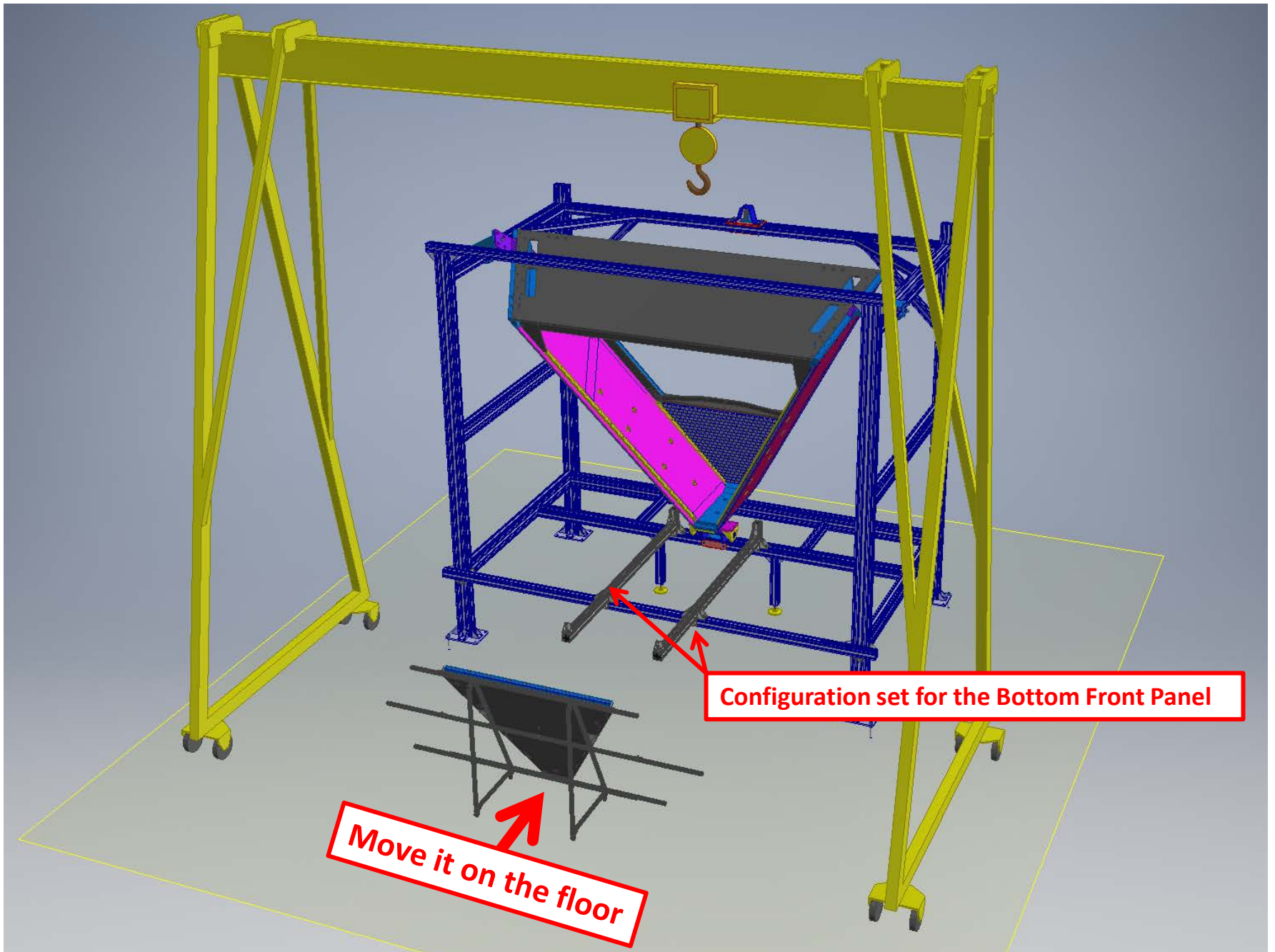

Inserting Bottom Front Panel - 2

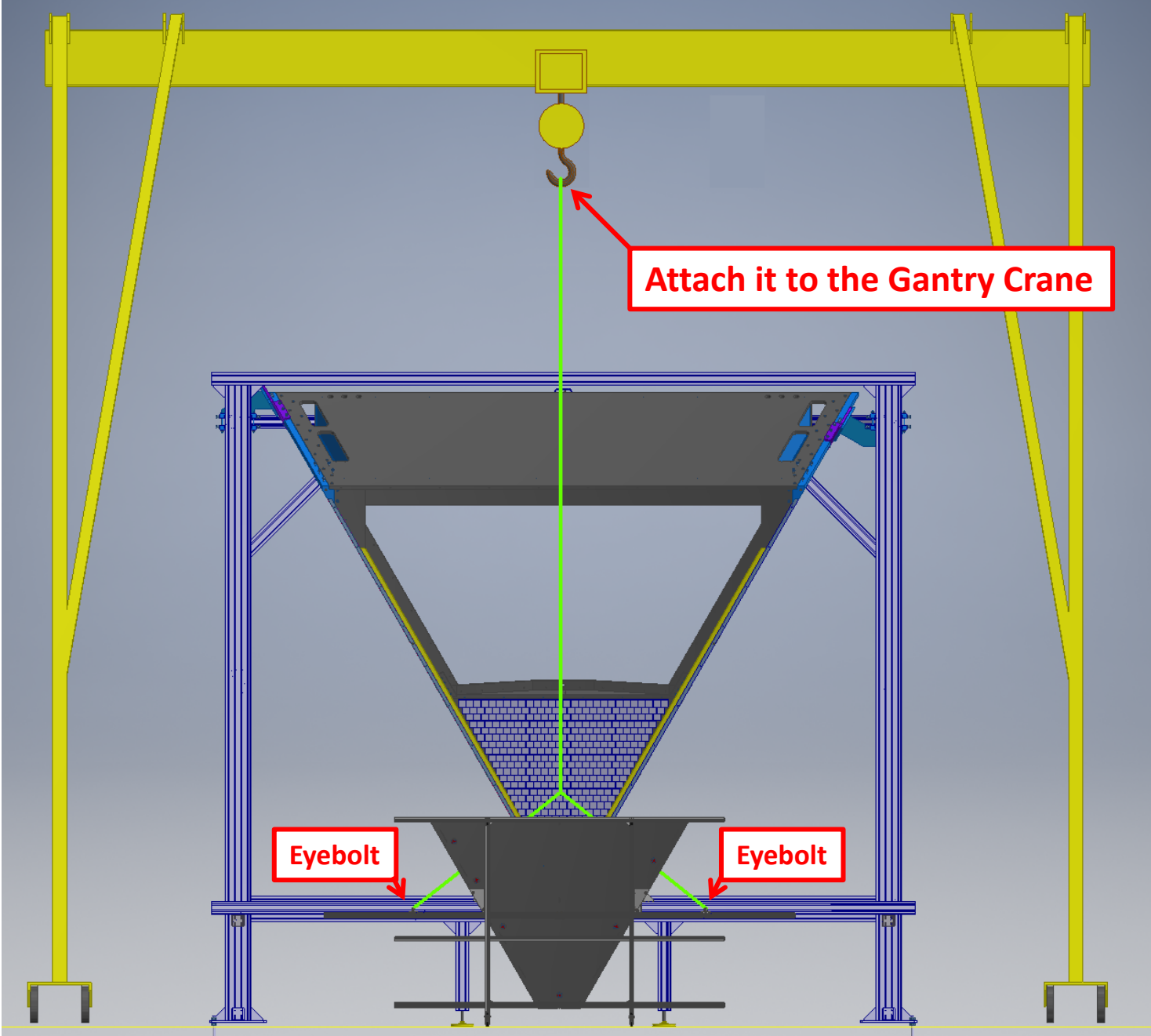

Inserting Bottom Front Panel - 3

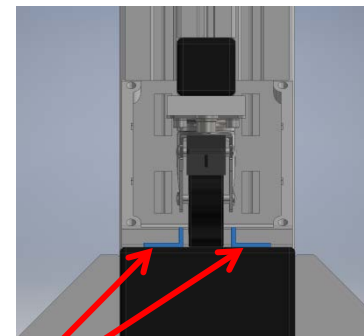
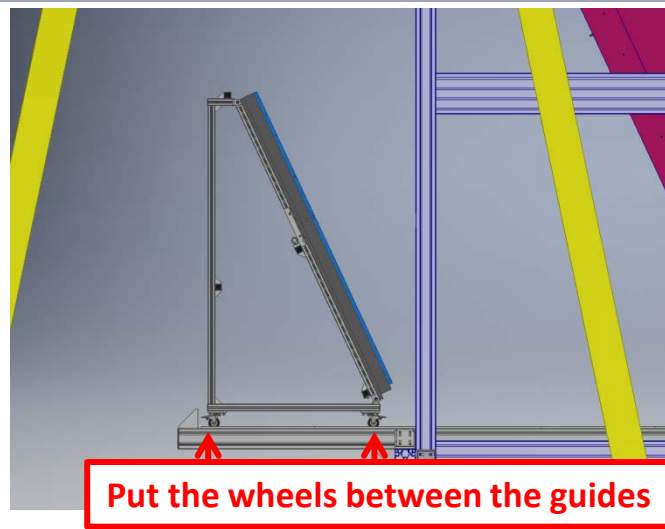
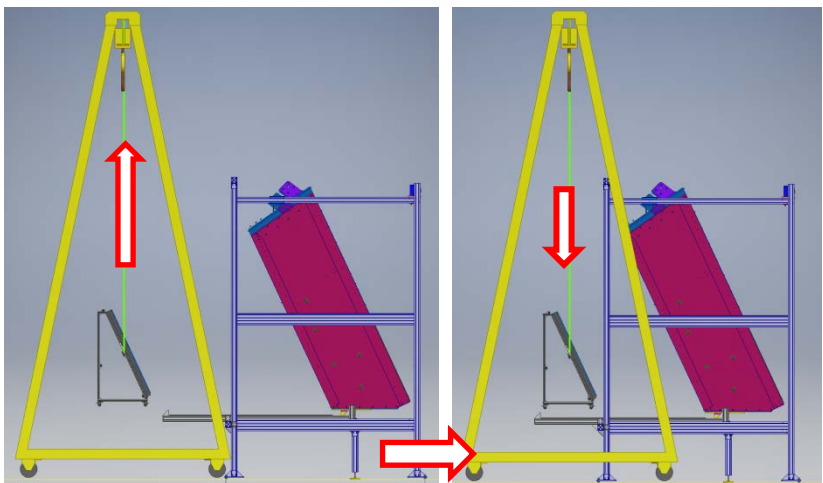
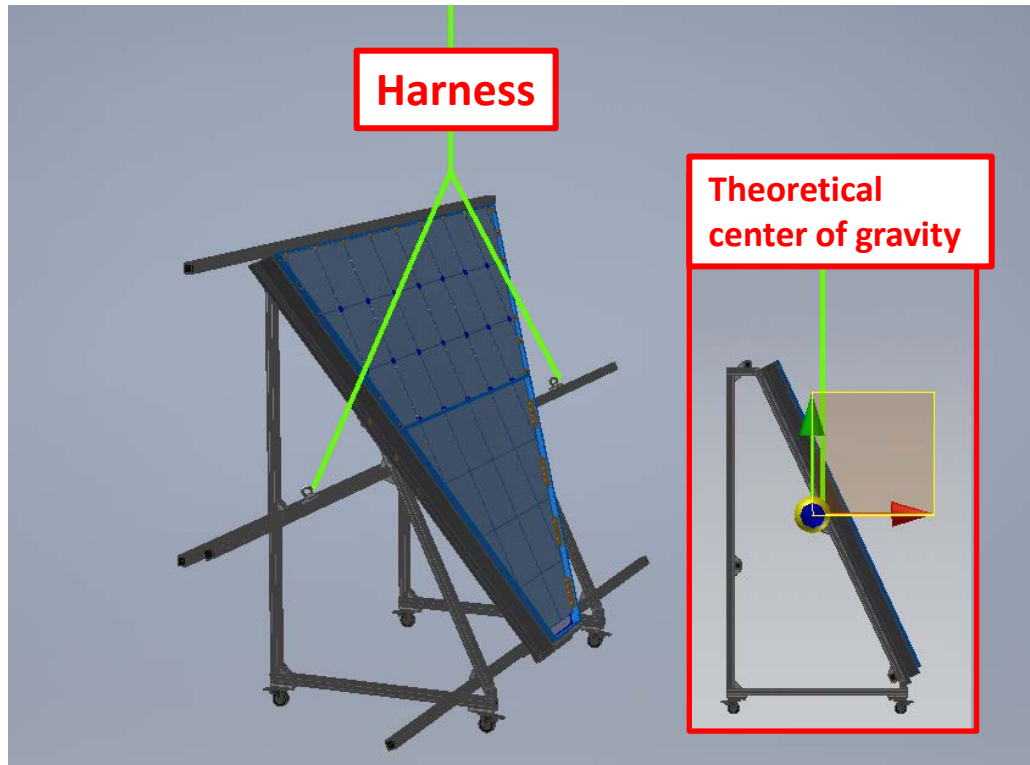
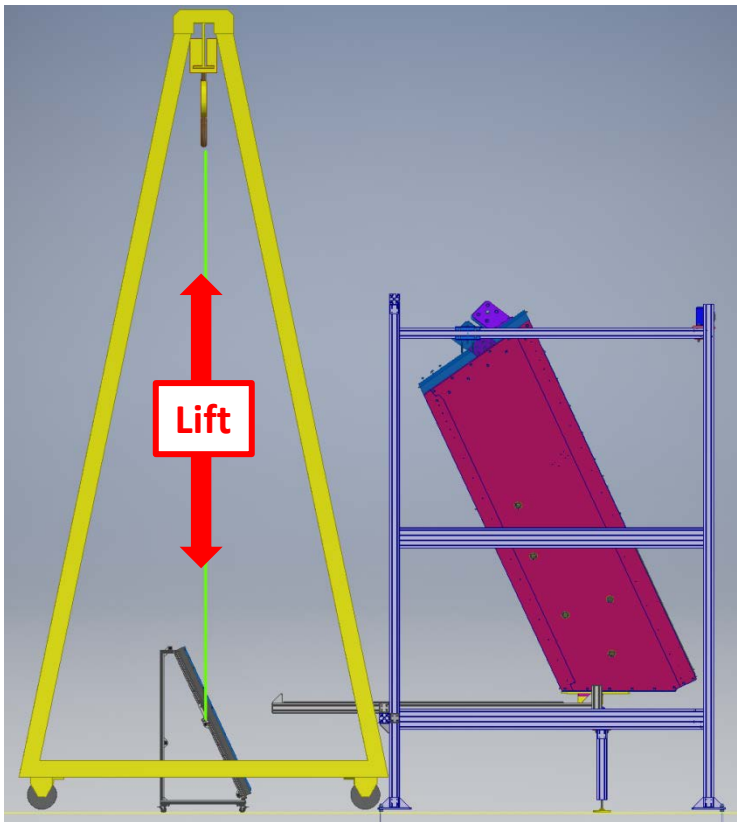

Inserting Bottom Front Panel - 4

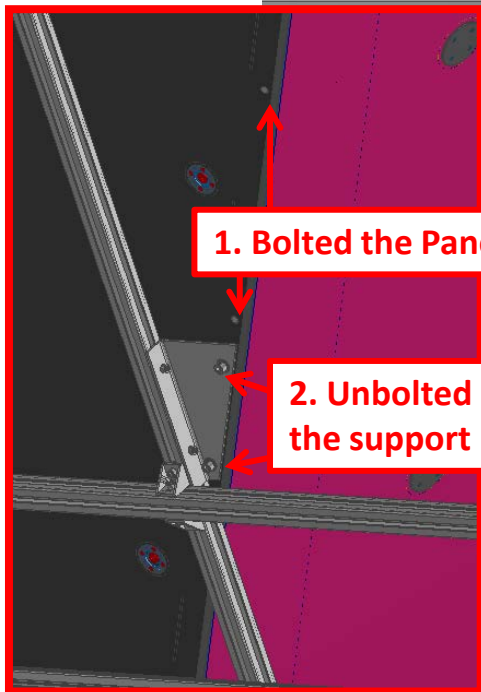
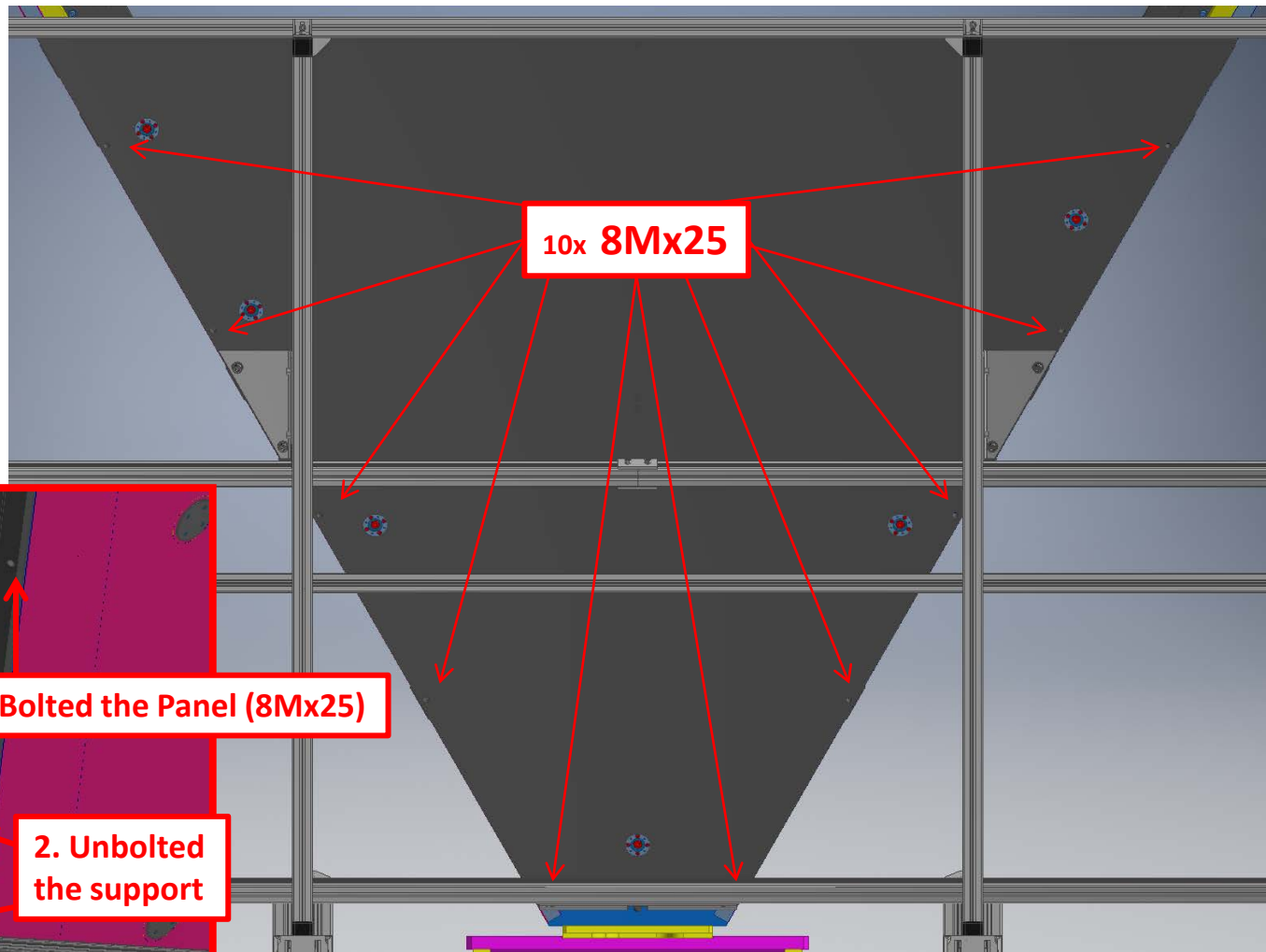
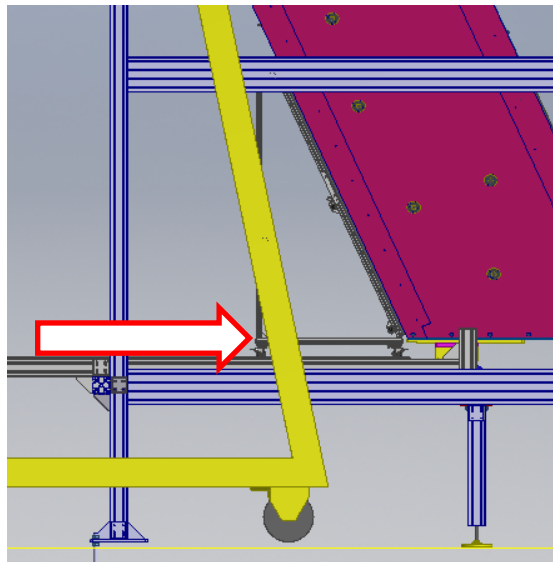

1. Bolted the Panel (8Mx25)

2. Unbolted the support

Inserting Top Front Panel - 1

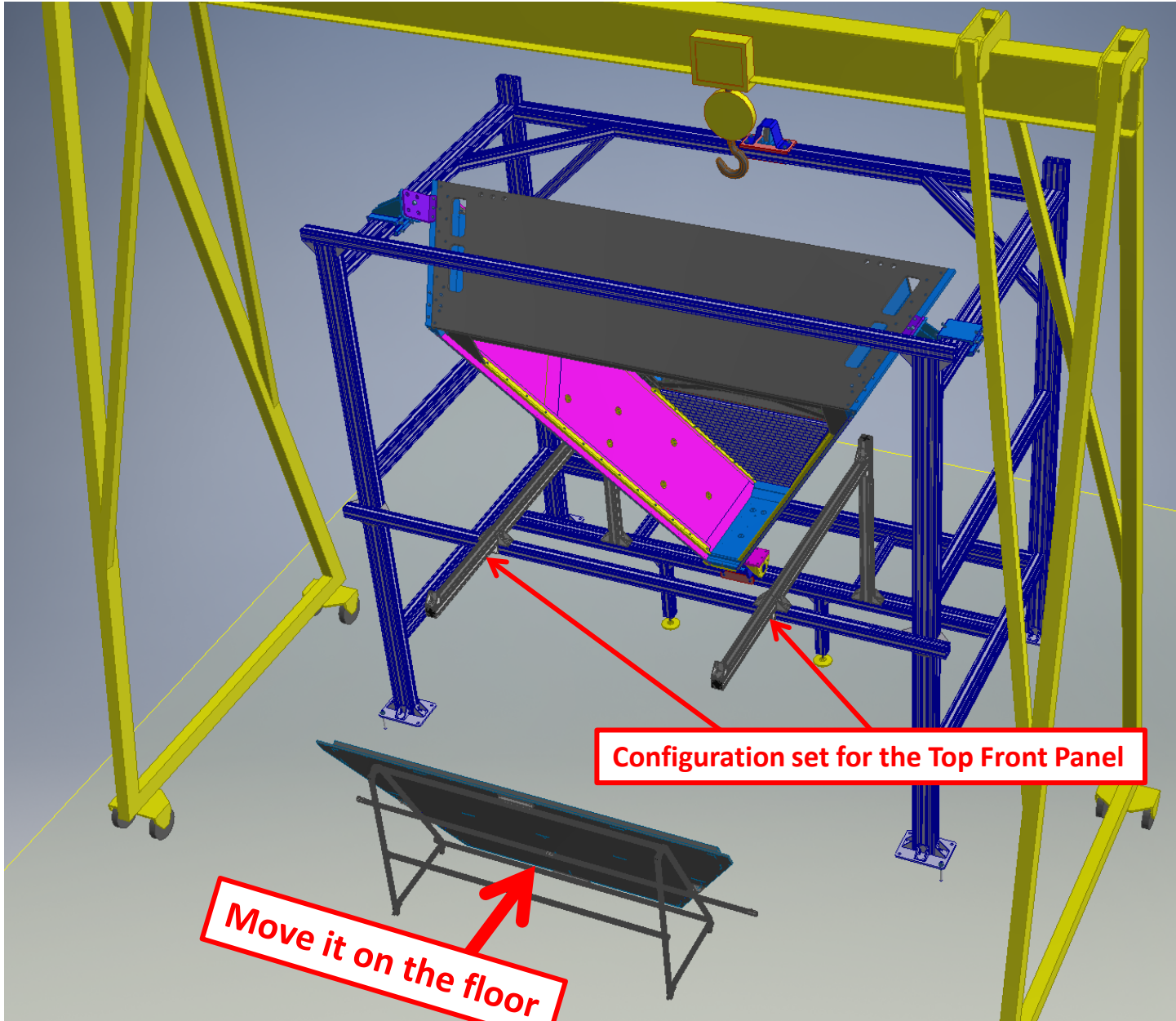

Inserting Top Front Panel - 2

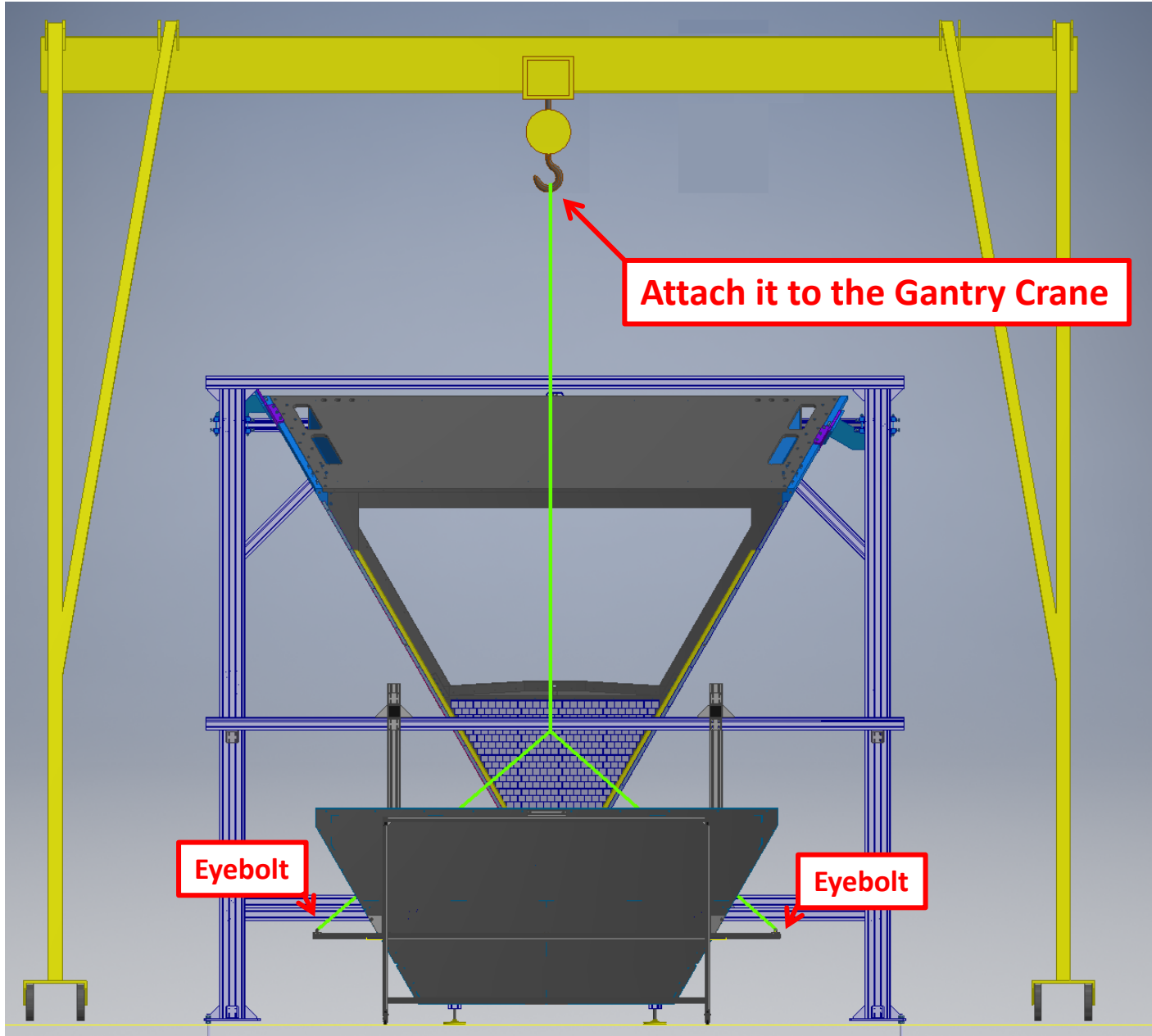

Inserting Top Front Panel - 3

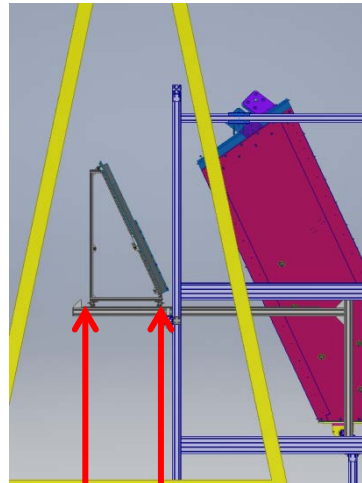
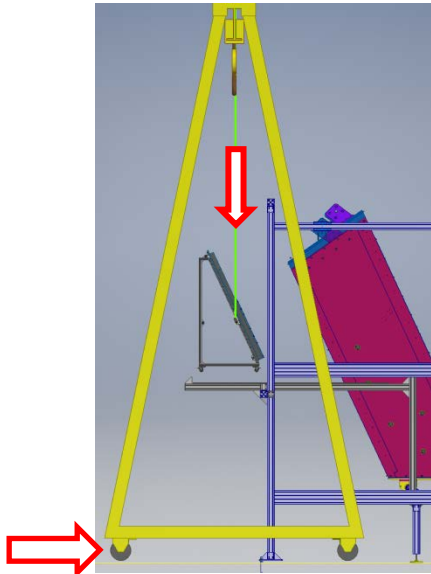
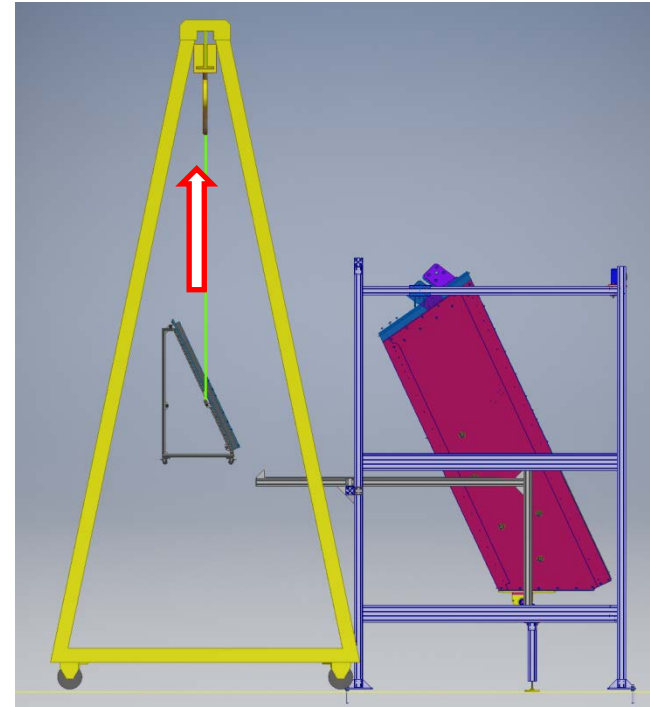
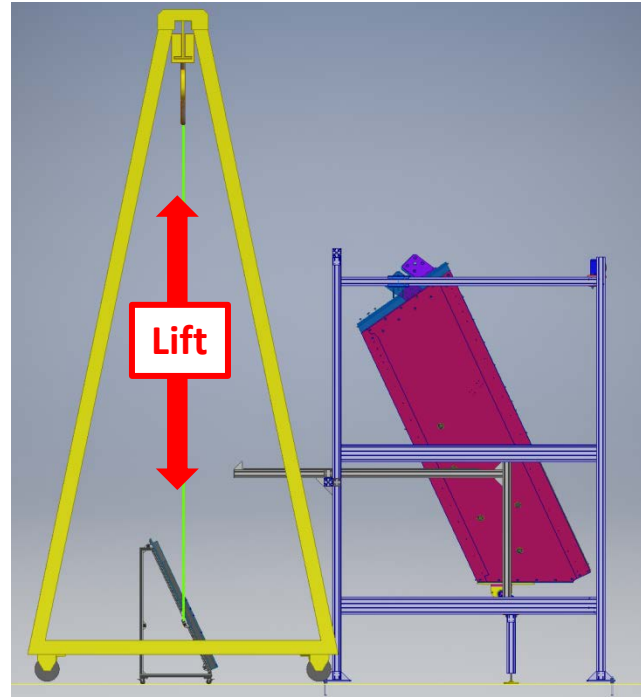
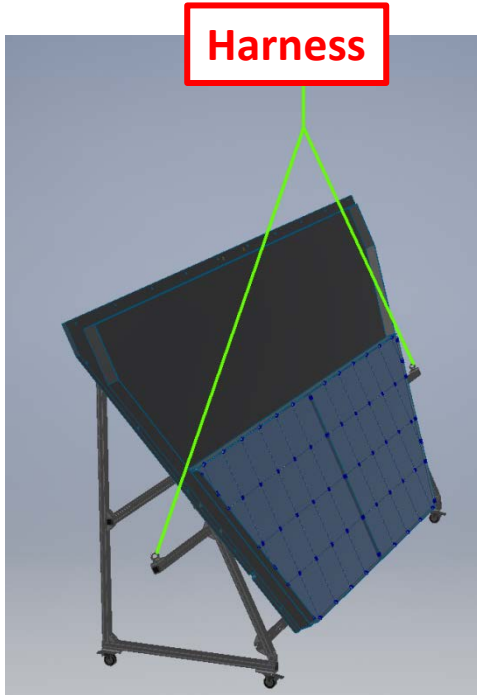

Put the wheels between the guides

Inserting Top Front Panel - 4

